

Geant 4

Simulation capabilities and application results

<http://cern.ch/geant4/>

<http://www.ge.infn.it/geant4/>

This presentation → <http://www.ge.infn.it/geant4/talks/>

Maria Grazia Pia

INFN Genova

Maria.Grazia.Pia@ge.infn.it

Technology transfer

Particle physics software aids space and medicine

Geant4 is a showcase example of technology transfer from particle physics to other fields such as space and medical science [...].

CERN Courier, June 2002



VOLUME 42 NUMBER 5 JUNE 2002

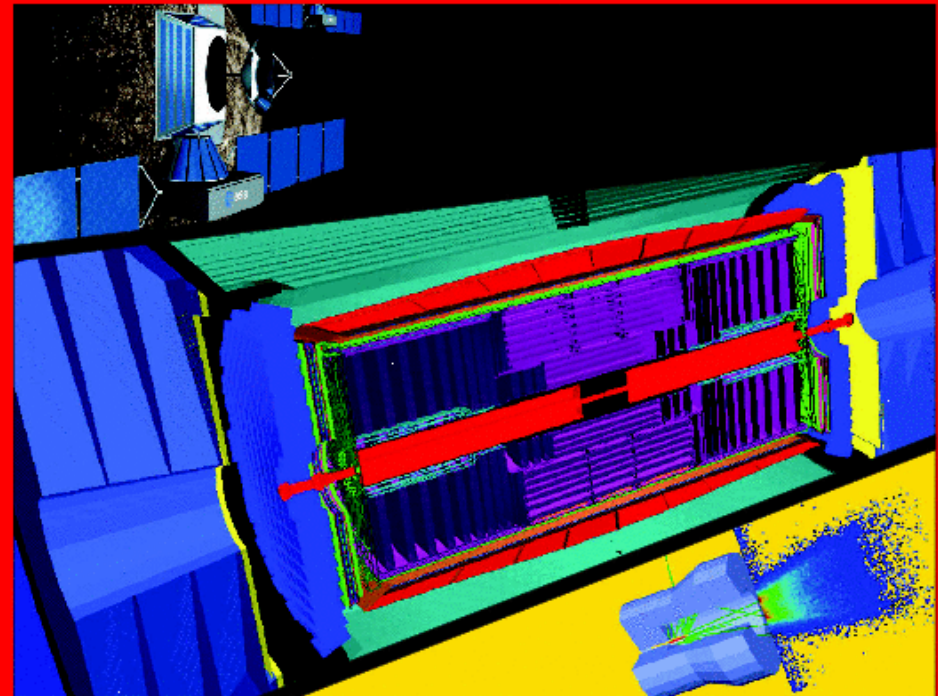

Simulation for physics, space and medicine

NEUTRINOS

Sudbury Neutrino Observatory confirms neutrino oscillation p5

TESLA

Electropolishing steers superconducting cavity to new record p10

COSMOPHYSICS

Joint symposium brings CERN, ESA and ESO together p15

United Nations World Summit on Information Society Geneva, December 2003

Geant4 – INFN presentation

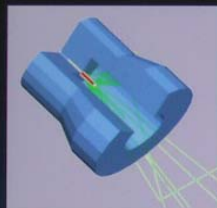

Precise physics models for radiation interactions with matter

Open source code providing advanced technologies to developing countries at no cost

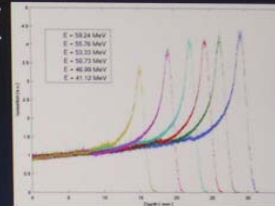

Accurate geometry and material modeling

Particle Physics Software aids Medicine
in the fight against cancer

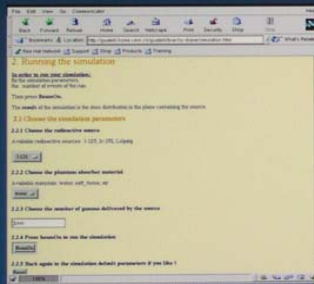

Friendly interface through the World Wide Web

Powerful data analysis tools

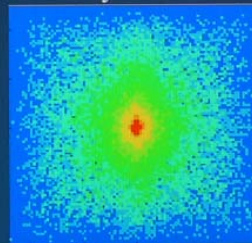

The GRID for fast and cheap processing on distributed computing resources



Courtesy CMS Collaboration

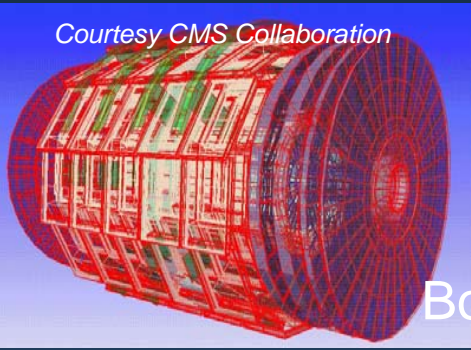

Geant 4

Born from the requirements of large scale HEP experiments

Courtesy K. Amako et al., KEK

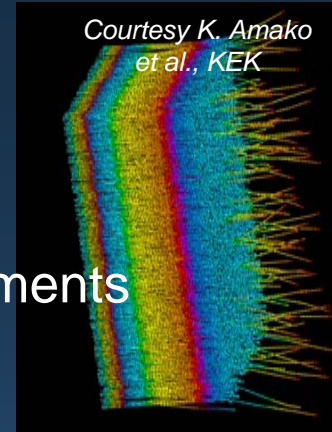

Widely used also in

- Space science and astrophysics
- Medical physics, nuclear medicine
- Radiation protection
- Accelerator physics
- Pest control, food irradiation
- Humanitarian projects, security
- etc.
- Technology transfer to industry, hospitals...

Courtesy ATLAS Collaboration

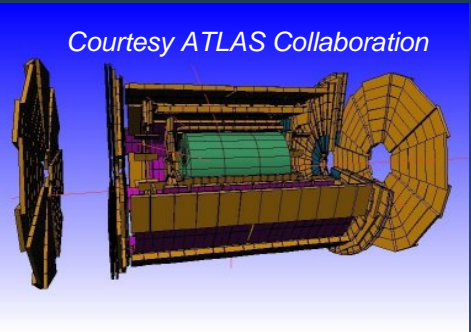

Courtesy H. Araujo and A. Howard, IC London

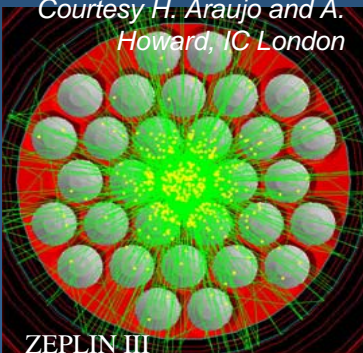

ZEPLIN III

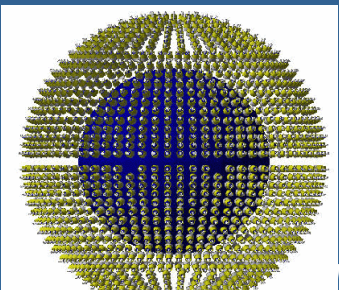

Courtesy Borexino

NFN Genova



Courtesy R. Nartallo et al., ESA

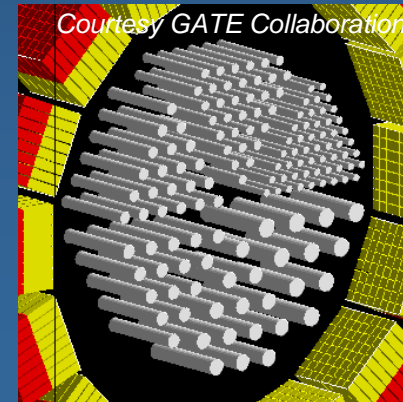
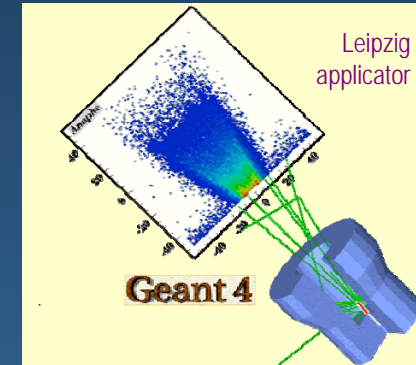

Courtesy GATE Collaboration

**Most cited
“engineering”
publication in the
past 2 years!**



scientific...

Globalisation

Sharing requirements and functionality
across diverse fields

Once upon a time
there was a X-ray telescope...

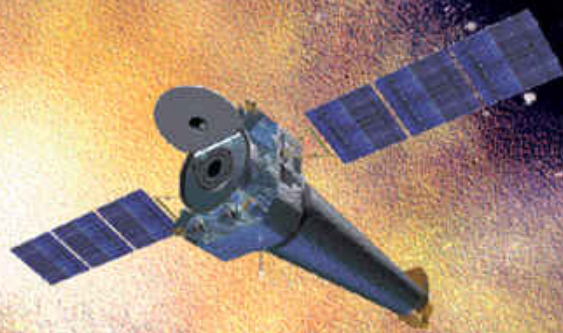

Chandra
X-Ray Observatory

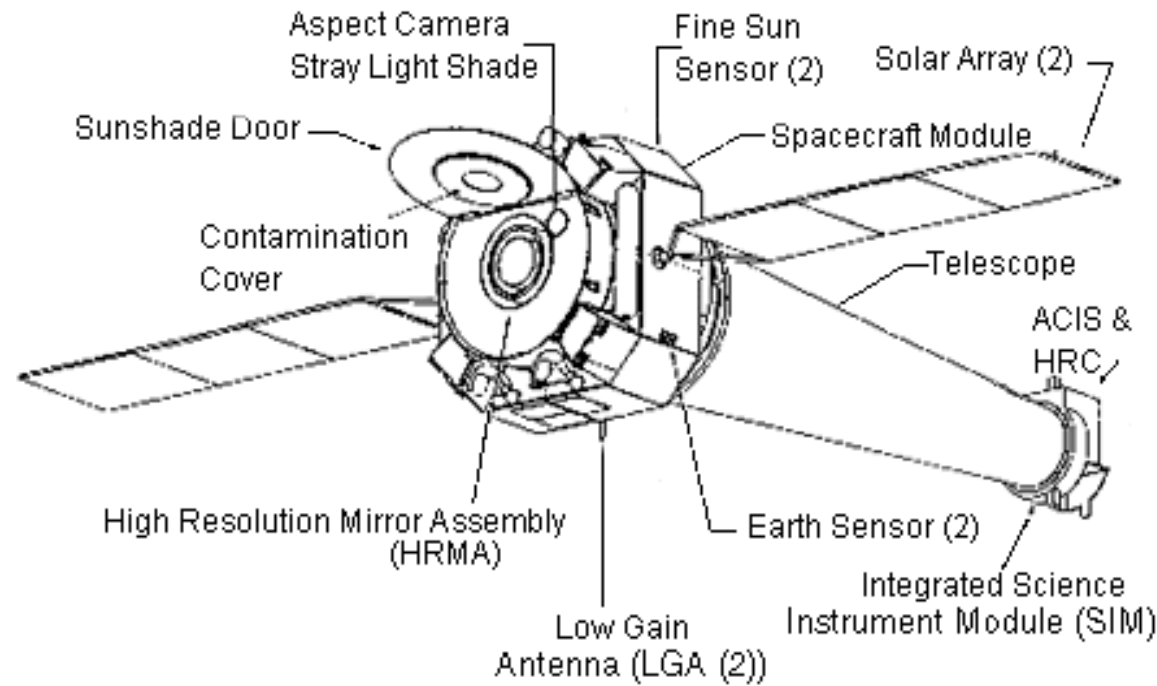

Courtesy of NASA/CXC/SAO

Chandra X-ray Observatory Status Update

September 14, 1999
MSFC/CXC

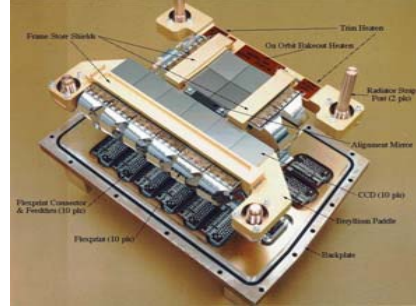

CHANDRA CONTINUES TO TAKE SHARPEST IMAGES EVER; TEAM STUDIES INSTRUMENT DETECTOR CONCERN

Normally every complex space facility encounters a few problems during its checkout period; even though Chandra's has gone very smoothly, the science and engineering team is working a concern with a portion of one science instrument.

The team is investigating a **reduction in the energy resolution** of one of two sets of X-ray detectors in the Advanced Charge-coupled Device Imaging Spectrometer (ACIS) science instrument.

A series of diagnostic activities to characterize the degradation, identify possible causes, and test potential remedial procedures is underway.

The degradation appeared in the **front-side** illuminated Charge-Coupled Device (CCD) chips of the ACIS. The instrument's **back-side** illuminated chips have shown no reduction in capability and continue to perform flawlessly.

What could be the source of detector damage?

- Radiation belt electrons?
- Scattered in the mirror shells?
- Effectiveness of magnetic “brooms”?
- Electron damage mechanism? - NIEL?
- Other particles? Protons, cosmics?



Requirements for low energy p in **Geant 4**

GEANT4 LOW ENERGY ELECTROMAGNETIC PHYSICS

User Requirements Document

Status: in CVS repository

Version: 2.4

Project: Geant4-LowE

Reference: LowE-URD-V2.4

Created: 22 June 1999

Last modified: 26 March 2001

Prepared by: Petteri Nieminen (ESA) and Maria Grazia Pia (INFN)

- **UR 2.1** The user shall be able to simulate electromagnetic interactions of positive charged hadrons down to < 1 KeV.
- **Need:** *Essential*
- **Priority:** *Required by end 1999*
- **Stability:** *Stable*
- **Source:** *Medical physics groups, PIXE*
- **Clarity:** *Clear*
- **Verifiability:** *Verified*

Geant 4 LowE Hadrons and Ions

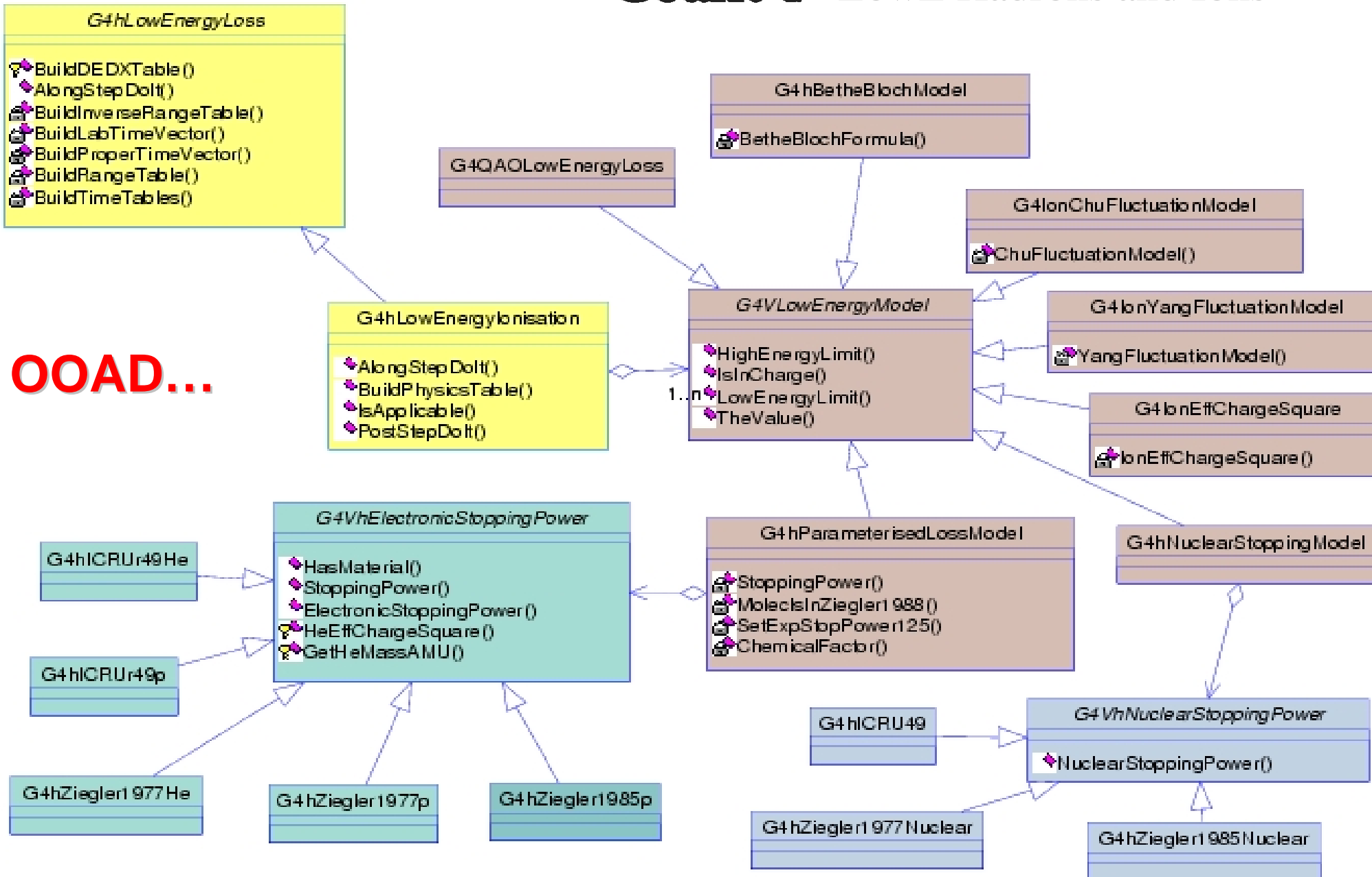

...and validation

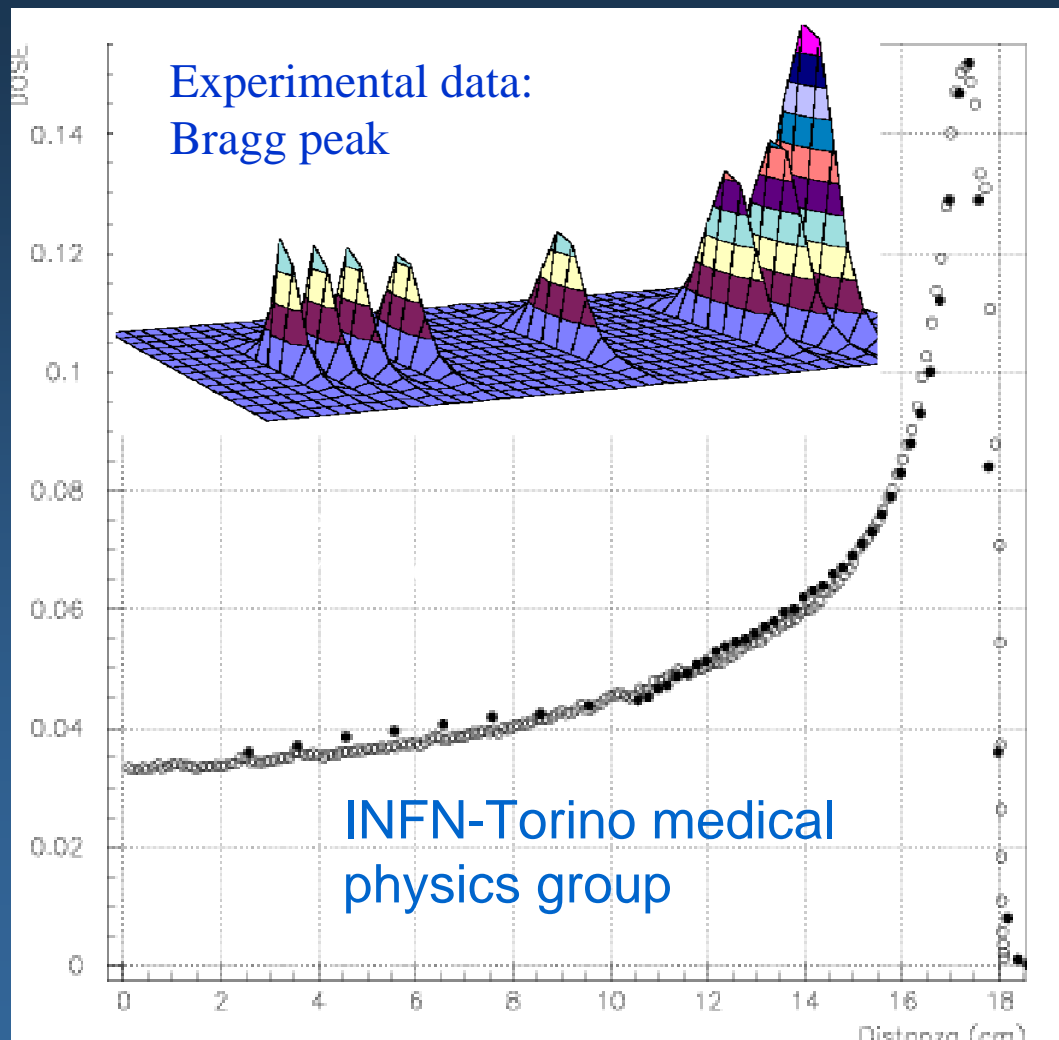

Courtesy of R. Gotta, Thesis

Maria Grazia Pia, INFN Genova

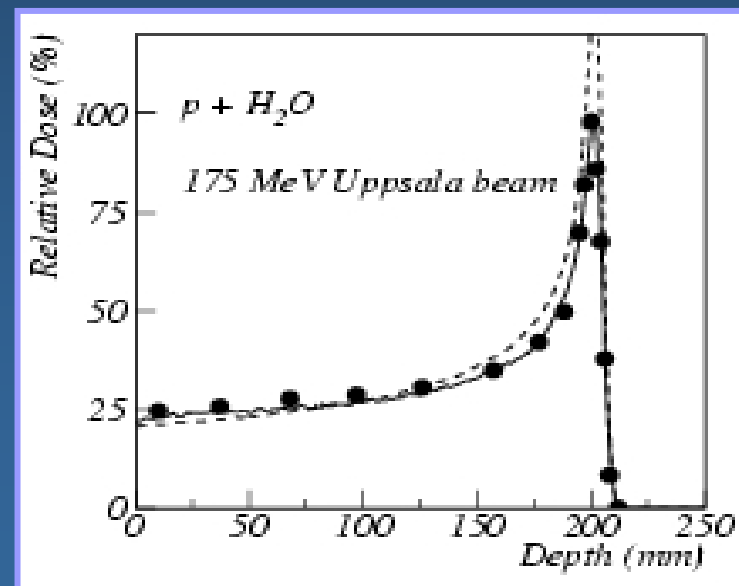
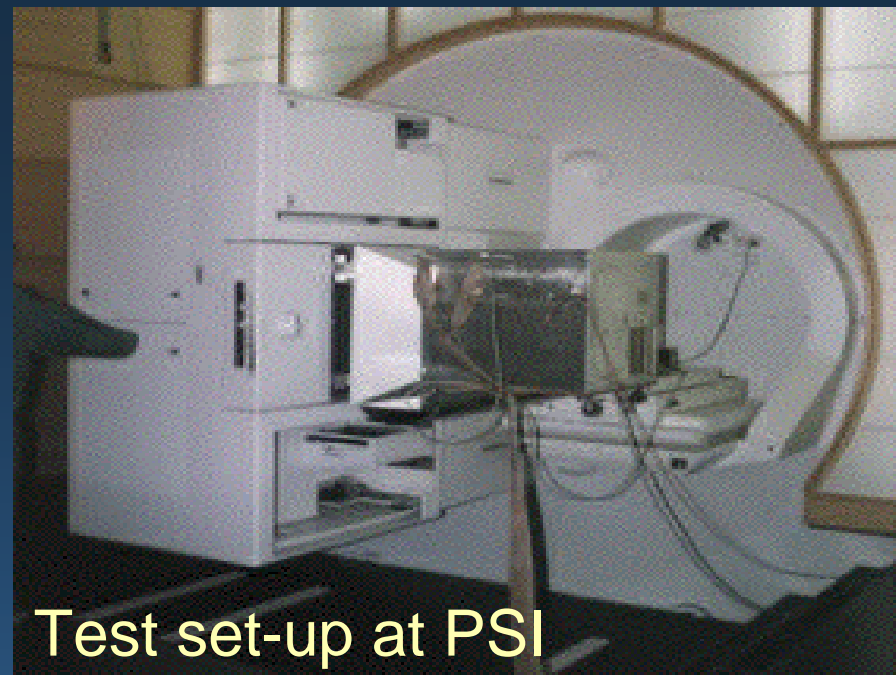

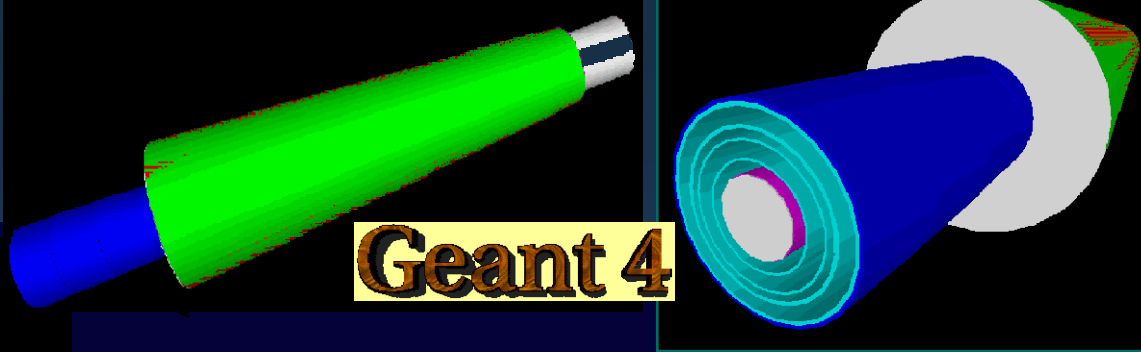

Geant4 LowE Working Group

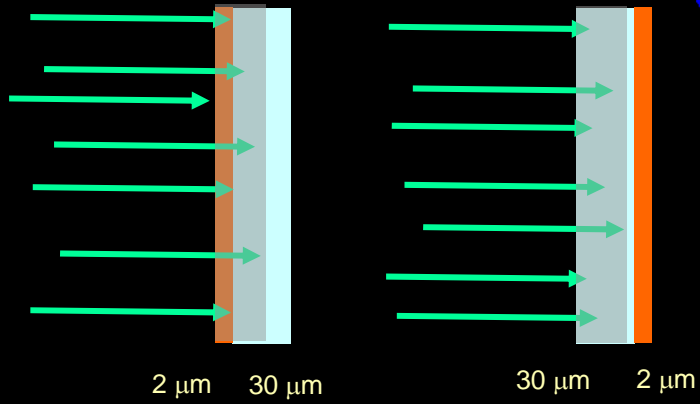

Geant 4



CCD displacement damage:
front vs. back-illuminated
 $30 \mu\text{m Si} \Rightarrow \sim 1.5 \text{ MeV p}^+$

 Active layer
 Passive layer

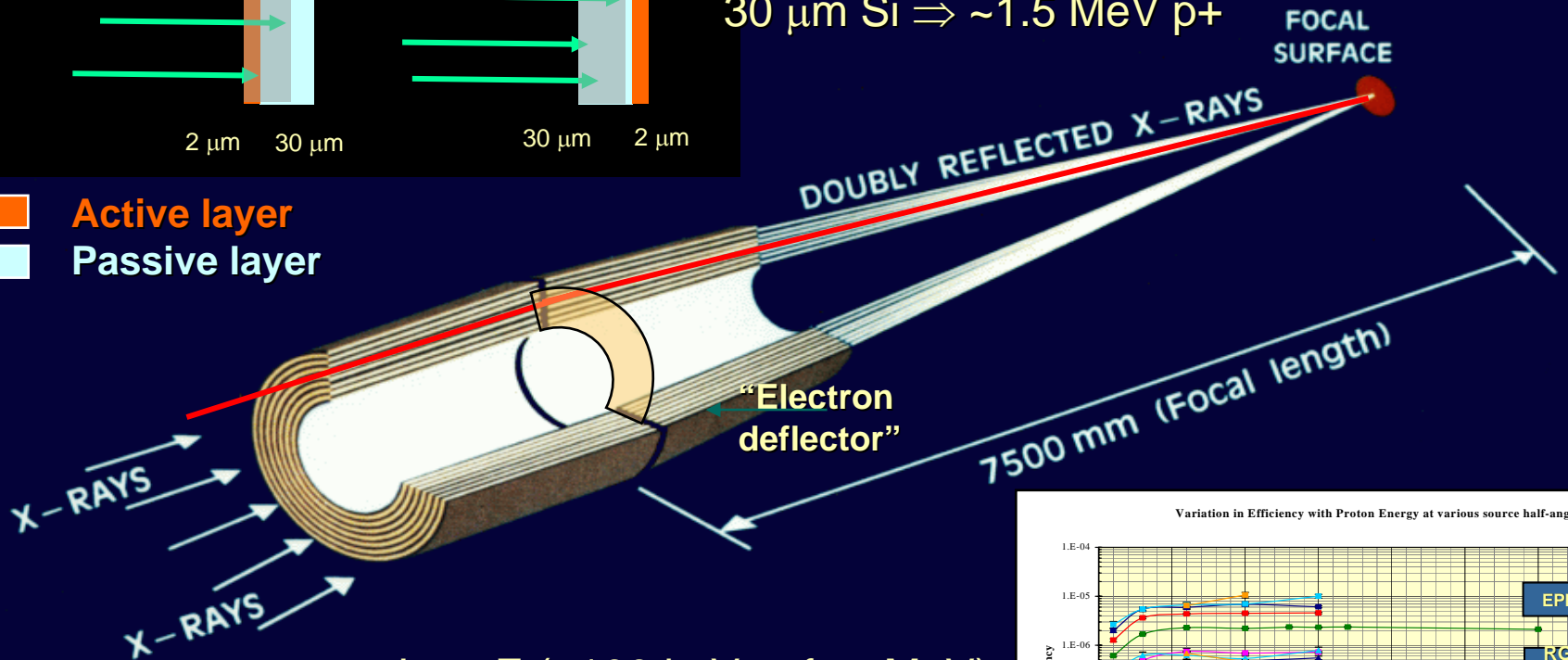

Low-E ($\sim 100 \text{ keV}$ to few MeV),
low-angle ($\sim 0^\circ$ - 5°) proton scattering

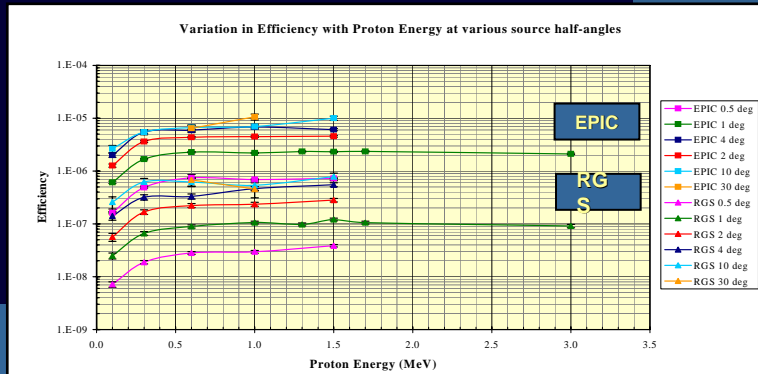



XMM-Newton was launched on 10 December 1999

Courtesy of R. Nartallo, ESA

XMM-Newton

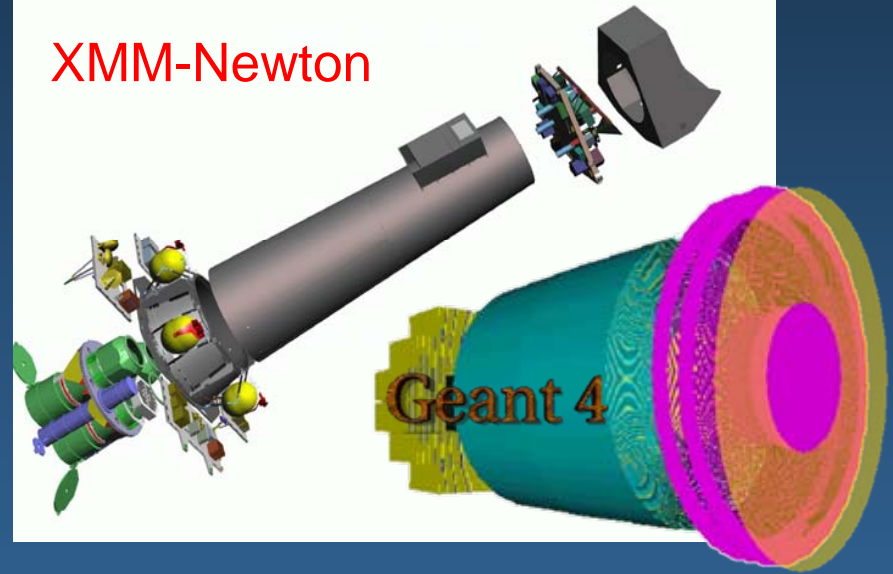

Simulation can be mission-critical!

(not only in a space mission...)

EPIC-PN image of the Coma Cluster

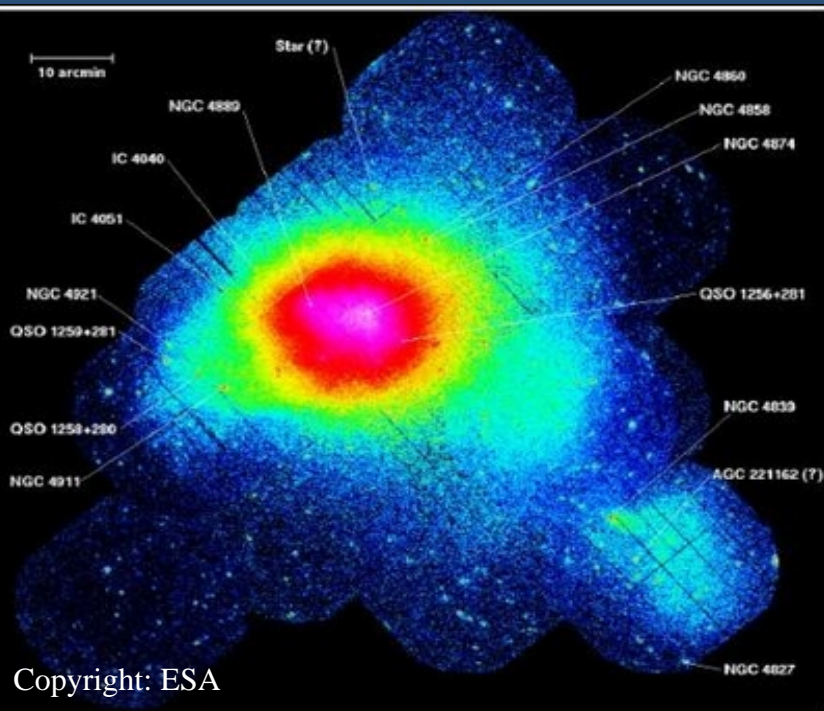

Copyright: ESA

...and the other way round

Geant4 low energy e, γ extensions

...were triggered by astrophysics requirements

X-Ray Surveys of Planets, Asteroids and Moons

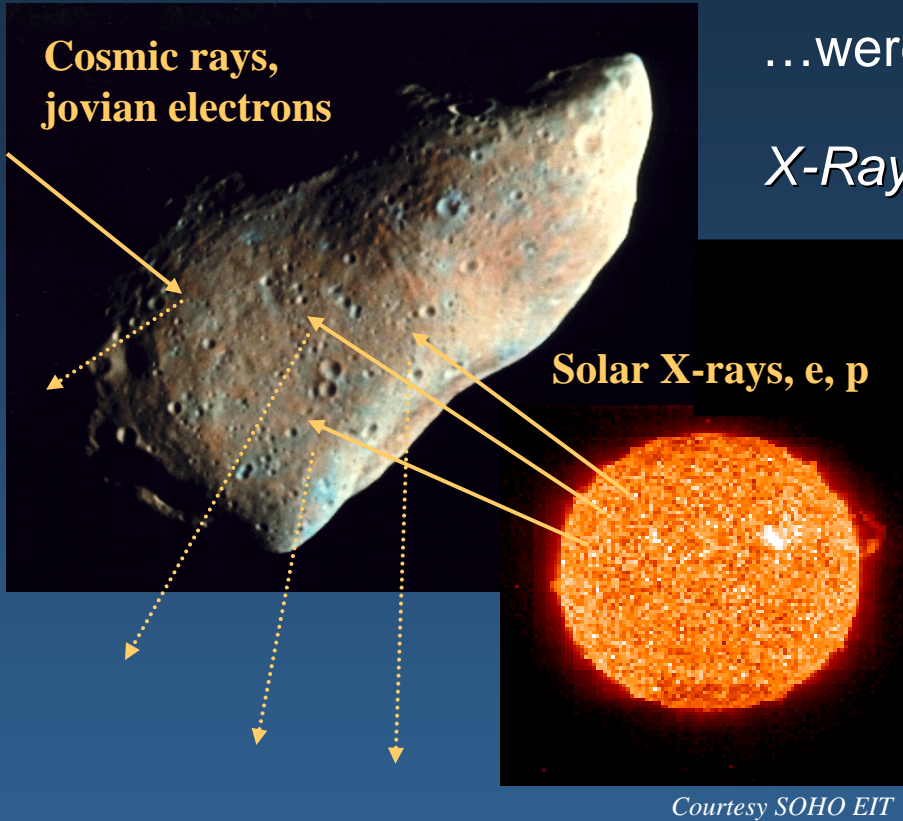

Induced X-ray line emission:
indicator of target composition
($\sim 100 \mu\text{m}$ surface layer)

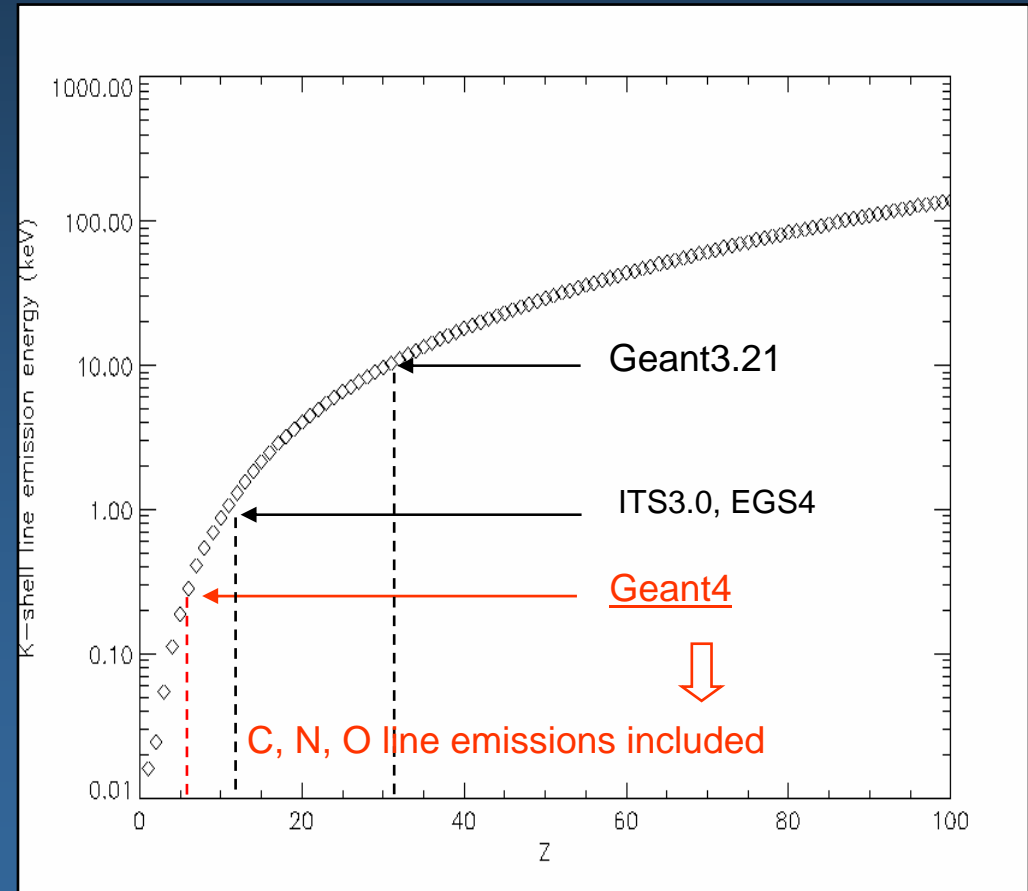

...the first user application

Goal: improve the biological effectiveness of titanium encapsulated ^{125}I sources in permanent prostate implants by exploiting X-ray fluorescence

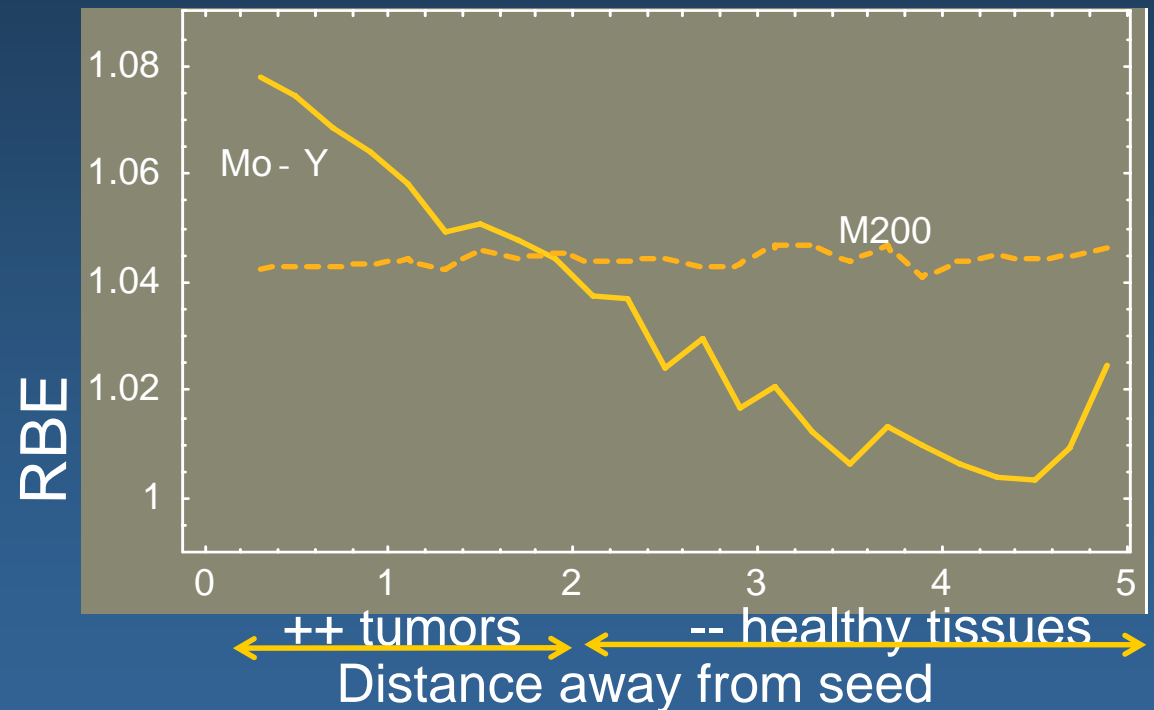
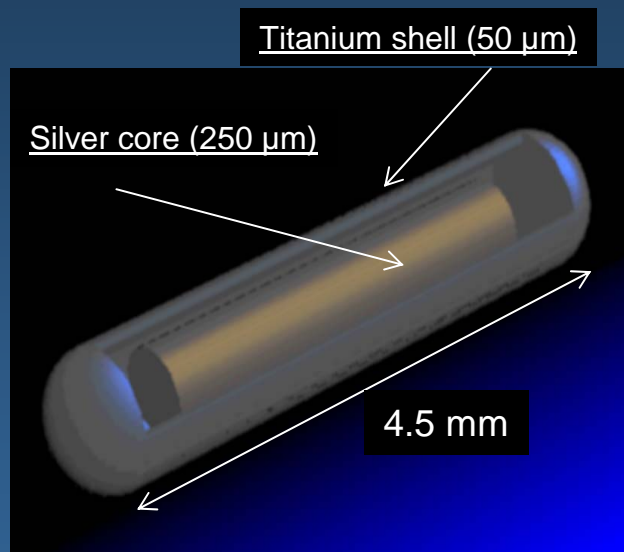

R. Taschereau, R. Roy, J. Pouliot

Centre Hospitalier Universitaire de Quebec, Dept. de radio-oncologie, Canada

Univ. Laval, Dept. de Physique, Canada

Univ. of California, San Francisco, Dept. of Radiation Oncology, USA

Maria Grazia Pia, INFN Genova

Gran Sasso Laboratory

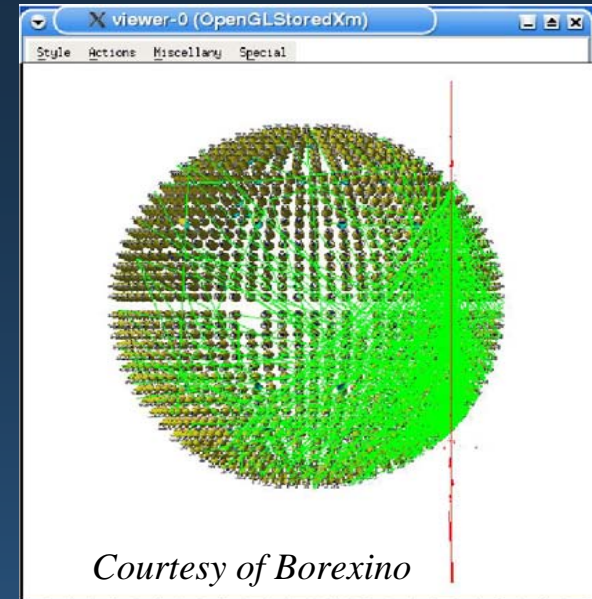

Courtesy of Borexino

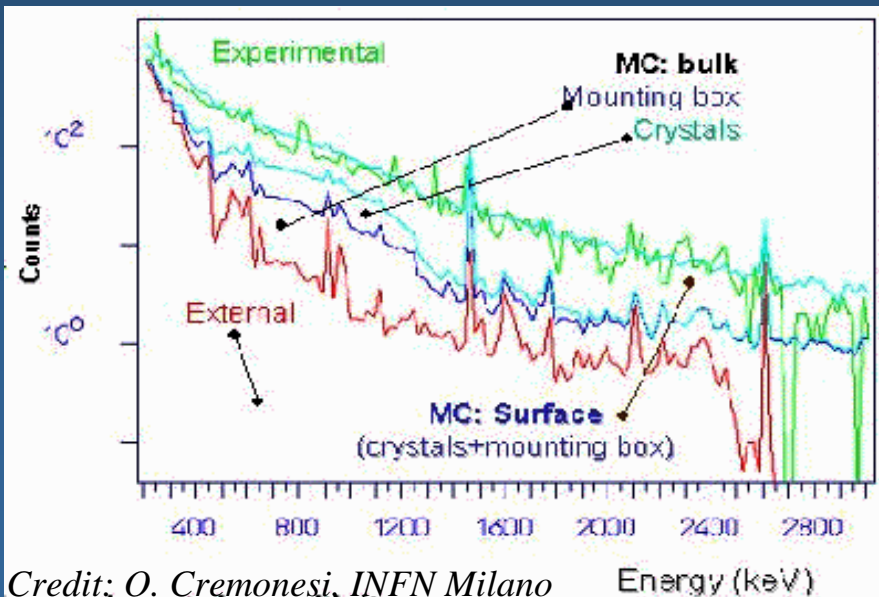

Credit: O. Cremonesi, INFN Milano

...back to HEP

- Similar requirements on low energy physics from underground neutrino and dark matter experiments
- Recent interest on these physics models from LHC for precision detector simulation

Publications on Medical Physics in 2004-2005 (1)

- 1) **Monte Carlo derivation of TG-43 dosimetric parameters for radiation therapy resources and 3M Cs-137 sources** ,
J. Pérez-Calatayud, D. Granero, F. Ballester, E. Casal, R. Cases, and S. Agramunt, Med. Phys. **32**, 2464 (2005)
- 2) **Octree based compression method of DICOM images for voxel number reduction and faster Monte Carlo**
V Hubert-Tremblay, L Archambault, L Beaulieu, and R Roy, Med. Phys. **32**, 2413 (2005)
- 3) **Simulation of Dosimetric Properties of Very-High Energy Laser-Accelerated Electron Beams**
T Fuchs, H Szymanowski, Y Glinec, J Faure, V Malka, and U Oelfke, Med. Phys. **32**, 2163 (2005)
- 4) **Quantum Efficiency of An MCP Detector: Monte Carlo Calculation**,
PM Shikhaliev, JL Ducote, T Xu, and S Molloi, Med. Phys. **32**, 2158 (2005)
- 6) **The Use of a Miniature Multileaf Collimator in Stereotactic Proton Therapy**
R Slopsema, H Paganetti, H Kooy, M Bussiere, J Sisterson, J Flanz, and T Bortfeld, Med. Phys. **32**, 2088 (2005)
- 7) **Simulation of Organ Specific Secondary Neutron Dose in Proton Beam Treatments**
H Jiang, B Wang, X Xu, H Suit, and H Paganetti, Med. Phys. **32**, 2071 (2005)
- 8) **Study of Truncated Cone Filters Using GEANT4**
T Himukai, Y Takada, and R Kohno, Med. Phys. **32**, 2030 (2005)
- 9) **Proton Dose Calculation Using Monte-Carlo-Validated Pencil Beam Database for KonRad Treatment Planning System**
A Trofimov, A Knopf, H Jiang, T Bortfeld, and H Paganetti, Med. Phys. **32**, 2030 (2005)
- 10) **Monte-Carlo Investigation of Proton-Generated Radioactivity in a Multileaf Collimator for a Proton Therapy Facility**
J McDonough, D Goulart, M Baldytchev, P Bloch, and R Maughan, Med. Phys. **32**, 2030 (2005)
- 11) **Energy Distributions of Proton Interactions in MCNPX and GEANT4 Codes Using a Slab Target**
B Wang, X George Xu, H Jiang, and H Paganetti, Med. Phys. **32**, 2029 (2005)
- 12) **Monte Carlo Calculation of the TG-43 Dosimetric Parameters of a New BEBIG Ir-192 HDR Source**
F Ballester, E Casal, D Granero, J Perez-Calatayud, S Agramunt, and R Cases, Med. Phys. **32**, 1952 (2005)

Publications on Medical Physics in 2004-2005 (2)

13) Comparison of Pencil Beam Algorithm and Monte Carlo Dose Calculation for Proton Therapy of Paranasal Sinus Cancer
H Jiang, J Adams, S Rosenthal, S Kollipara, and H Paganetti, Med. Phys. **32**, 2028 (2005)

14) Clinical Implementation of Proton Monte Carlo Dose Calculation
H Paganetti, H Jiang, and S Kollipara, Med. Phys. **32**, 2028 (2005)

15) Validation of a Monte Carlo Algorithm for Simulation of Dispersion Due to Scattering of a Monoenergetic Proton Beam
D Goulart, S Avery, R Maughan, and J McDonough, Med. Phys. **32**, 2019 (2005)

16) Monte Carlo Simulations of the Dosimetric Characteristics of a New Multileaf Collimator
M Tacke, H Szymanowski, C Schulze, S Nuss, E Wehrwein, S Leidenberger, and U Oelfke, Med. Phys. **32**, 2018 (2005)

17) Verification of Monte Carlo Simulations of Proton Dose Distributions in Biological Media
H Szymanowski, S Nill, and U Oelfke, Med. Phys. **32**, 2014 (2005)

18) Octree Based Compression Method of DICOM Images for Voxel Number Reduction and Faster Monte Carlo Simulations
V Hubert-Tremblay, L Archambault, L Beaulieu, and R Roy, Med. Phys. **32**, 2013 (2005)

19) Design Characteristics of a MLC for Proton Therapy
S Avery, D Goulart, R Maughan, and J McDonough, Med. Phys. **32**, 2012 (2005)

20) Clinical Impact of Seed Density and Prostate Elemental Composition On Permanent Seed Implant Dosimetry
J Carrier, F Therriault-Proulx, R Roy, and L Beaulieu, Med. Phys. **32**, 2011 (2005)

21) Monte Carlo Dosimetric Study of the New BEBIG Co-60 HDR Source
J Perez-Calatayud, D Granero, F Ballester, E Casal, S Agramunt, and R Cases, Med. Phys. **32**, 1958 (2005)

22) Monte Carlo Derivation of TG-43 Dosimetric Parameters for Radiation Therapy Resources and 3M Cs-137 Sources
E Casal, D Granero, F Ballester, J Perez-Calatayud, S Agramunt, and R Cases, Med. Phys. **32**, 1952 (2005)

Publications on Medical Physics in 2004-2005 (3)

23) PSF and S/P in Mammography: A Validation of Simulations Using the GEANT4 Code

V Grabski, M-E Brandan, C. Ruiz-Trejo, and Y. Villaseñor, Med. Phys. **32**, 1911 (2005)

24) Validation of GATE Monte Carlo Simulations of the Noise Equivalent Count Rate and Image Quality for the GE Discovery LS PET Scanner

CR Schmidlein, AS Kirov, SA Nehmeh, LM Bidaut, YE Erdi, KA Hamacher, JL Humm, and HI Amols, Med. Phys. **32**, 1900 (2005)

25) SU-EE-A2-05: Accuracy in the Determination of Microcalcification Thickness in Digital Mammography

M-E Brandan and V Grabski, Med. Phys. **32**, 1898 (2005)

26) Accuracy of the photon and electron physics in GEANT4 for radiotherapy applications

Emily Poon and Frank Verhaegen, Med. Phys. **32**, 1696 (2005)

27) Density resolution of proton computed tomography,

Reinhard W. Schulte, Vladimir Bashkirov, Márgio C. Loss Klock, Tianfang Li, Andrew J. Wroe, Ivan Evseev, David C. Williams, and Todd Satogata, Med. Phys. **32**, 1035 (2005)

28) The role of nonelastic reactions in absorbed dose distributions from therapeutic proton beams in different medium

Andrew J. Wroe, Iwan M. Cornelius, and Anatoly B. Rosenfeld, Med. Phys. **32**, 37 (2005)

29) Monte Carlo and experimental derivation of TG43 dosimetric parameters for CSM-type Cs-137 sources

J. Pérez-Calatayud, D. Granero, E. Casal, F. Ballester, and V. Puchades, Med. Phys. **32**, 28 (2005)

30) Dosimetric study of the 15 mm ROPES eye plaque

D. Granero, J. Pérez-Calatayud, F. Ballester, E. Casal, and J. M. de Frutos, Med. Phys. **31**, 3330 (2004)

31) Monte Carlo dosimetric study of Best Industries and Alpha Omega Ir-192 brachytherapy seeds

F. Ballester, D. Granero, J. Pérez-Calatayud, E. Casal, and V. Puchades, Med. Phys. **31**, 3298 (2004)

Publications on Medical Physics in 2004-2005 (4)

32) Adaptation of GEANT4 to Monte Carlo dose calculations based on CT data

H. Jiang and H. Paganetti, Med. Phys. **31**, 2811 (2004)

33) Accurate Monte Carlo simulations for nozzle design, commissioning and quality assurance for a proton radiation therapy facility

H. Paganetti, H. Jiang, S.-Y. Lee, and H. M. Kooy, Med. Phys. **31**, 2107 (2004)

34) Phantom size in brachytherapy source dosimetric studies

J. Pérez-Calatayud, D. Granero, and F. Ballester, Med. Phys. **31**, 2075 (2004)

35) Monte Carlo dosimetric characterization of the Cs-137 selectron/LDR source: Evaluation of applicator attenuation and superposition approximation effects

J. Pérez-Calatayud, D. Granero, F. Ballester, V. Puchades, and E. Casal, Med. Phys. **31**, 493 (2004)

36) Validation of GEANT4, an object-oriented Monte Carlo toolkit, for simulations in medical physics

J.-F. Carrier, L. Archambault, L. Beaulieu, and R. Roy, Med. Phys. **31**, 484 (2004)

37) Dosimetry characterization of ³²P intravascular brachytherapy source wires using Monte Carlo codes PENELOPE and GEANT4,

Javier Torres, Manuel J. Buades, Julio F. Almansa, Rafael Guerrero, and Antonio M. Lallena, Med. Phys. **31**, 296 (2004)

Publications on Physics in Medicine and Biology in 2004-2005 (1)

1) Neutrons from fragmentation of light nuclei in tissue-like media: a study with the GEANT4 toolkit

Pshenichnov I, Mishustin I, Greiner W, Phys Med Biol. **50** No 23, 5493-5507.

2) Monte Carlo dosimetric study of the BEBIG Co-60 HDR source.

Ballester F, Granero D, Perez-Calatayud J, Casal E, Agramunt S, Cases R., Phys Med Biol. **50** No 21, 309-316

3) Monte Carlo simulation and scatter correction of the GE advance PET scanner with SimSET and Geant4

Barret O, Carpenter TA, Clark JC, Ansorge RE, Fryer TD, Phys Med Biol. **50** No 20, 4823-4840.

4) GATE: a simulation toolkit for PET and SPECT

S Jan, G Santin, D Strul, S Staelens, K Assié, D Autret, S Avner, R Barbier, M Bardiès, P M Bloomfield, D Brasse, V Breton, P Bruyndonckx, I Buvat, A F Chatziioannou, Y Choi, Y H Chung, C Comtat, D Donnarieix, L Ferrer, S J Glick, C J Groiselle, Guez, P-F Honore, S Kerhoas-Cavata, A S Kirov, V Kohli, M Koole, M Krieguer, D J van der Laan, F Lamare, G Largeron, Lartizien, D Lazaro, M C Maas, L Maigne, F Mayet, F Melot, C Merheb, E Pennacchio, J Perez, U Pietrzyk, F R Rannou, Rey, D R Schaart, C R Schmidlein, L Simon, T Y Song, J-M Vieira, D Visvikis, R Van de Walle, E Wieërs and C Morel
Phys. Med. Biol. **49** No 19, 4543-4561

5) Monte Carlo simulations of a scintillation camera using GATE: validation and application modelling

S Staelens, D Strul, G Santin, S Vandenberghe, M Koole, Y D'Asseler, I Lemahieu and R V de Walle
Phys. Med. Biol. **48** No 18, 3021-3042

6) Simulation of organ-specific patient effective dose due to secondary neutrons in proton radiation treatment

Hongyu Jiang, Brian Wang, X George Xu, Herman D Suit and Harald Paganetti
Phys. Med. Biol. **50** No 18, 4337-4353

7) Validation of the Monte Carlo simulator GATE for indium-111 imaging

K Assié, I Gardin, P Véra and I Buvat, Phys. Med. Biol. 50 No 13, 3113-3125

Publications on Physics in Medicine and Biology in 2004-2005 (2)

8) Integrating a MRI scanner with a 6 MV radiotherapy accelerator: dose increase at tissue–air interfaces in a lateral magnetic field due to returning electrons

A J E Raaijmakers, B W Raaymakers and J J W Lagendijk, Phys. Med. Biol. **50** No 7, 1363-1376

9) Consistency test of the electron transport algorithm in the GEANT4 Monte Carlo code

Emily Poon, Jan Seuntjens and Frank Verhaegen, Phys. Med. Biol. **50** No 4, 681-694

10) Monte Carlo evaluation of kerma in an HDR brachytherapy bunker

J Pérez-Calatayud, D Granero, F Ballester, E Casal, V Crispin, V Puchades, A León and G Verdú, Phys. Med. Biol. **49** No 24, 389-396

11) Optimizing Compton camera geometries

Sudhakar Chelikani, John Gore and George Zubal, Phys. Med. Biol. **49** No 8, 1387-1408

12) Four-dimensional Monte Carlo simulation of time-dependent geometries

H Paganetti, Phys. Med. Biol. **49** No 6, 75-81

13) Validation of the GATE Monte Carlo simulation platform for modelling a CsI(Tl) scintillation camera dedicated to small-animal imaging

D Lazaro, I Buvat, G Loudos, D Strul, G Santin, N Giokaris, D Donnarieix, L Maigne, V Spanoudaki, S Styliaris, S Staelens and V Breton, Phys. Med. Biol. **49** No 2, 271-285

14) Monte Carlo simulations of a scintillation camera using GATE: validation and application modelling

S Staelens, D Strul, G Santin, S Vandenberghe, M Koole, Y D'Asseler, I Lemahieu and R V de Walle, Phys. Med. Biol. **48** No 18, 3021-3042

...and many more: publications in IEEE Trans. Nucl. Sci. and IEEE Trans. Med. Imag. etc.

What is Geant 4?

OO Toolkit for the simulation of next generation HEP detectors

...of the current generation

...not only of HEP detectors

also...

An experiment of distributed software production and management

An experiment of application of rigorous software engineering methodologies and of the Object Oriented technology to the HEP environment

R&D phase: **RD44**, 1994 - 1998

1st release: December 1998

2 new releases/year since then

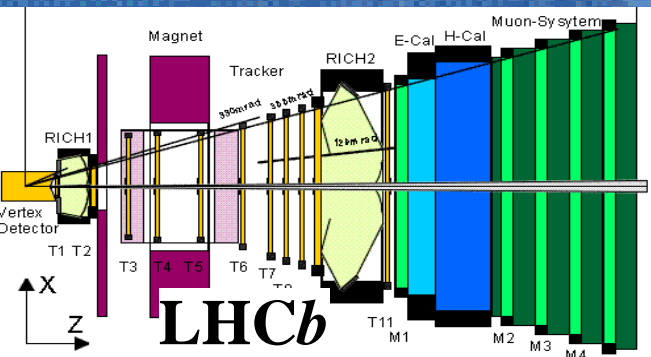

Complex physics
 Complex detectors
 20 years software life-span

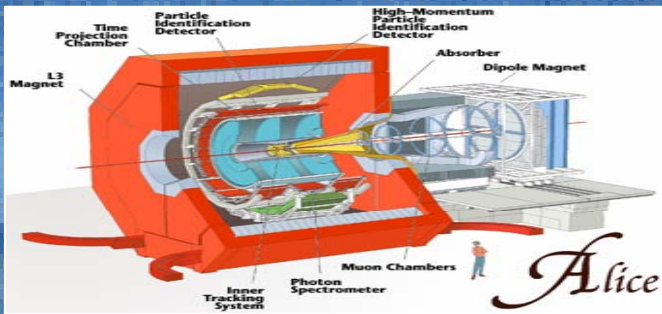

LHC

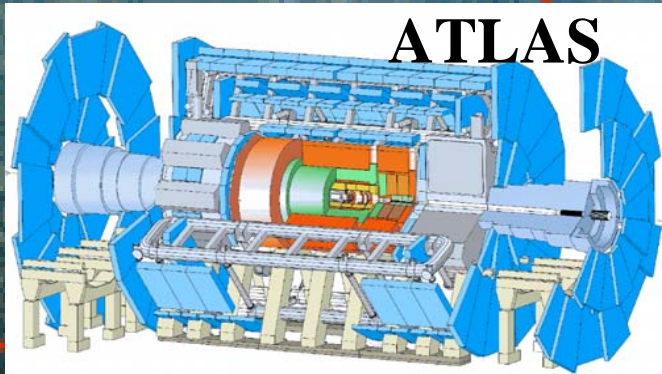
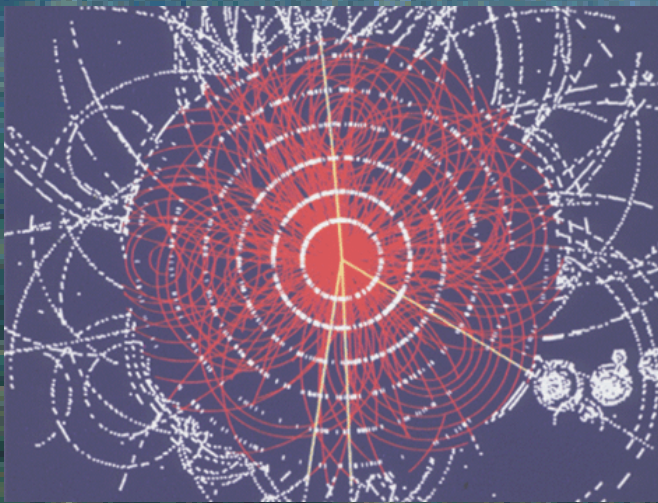
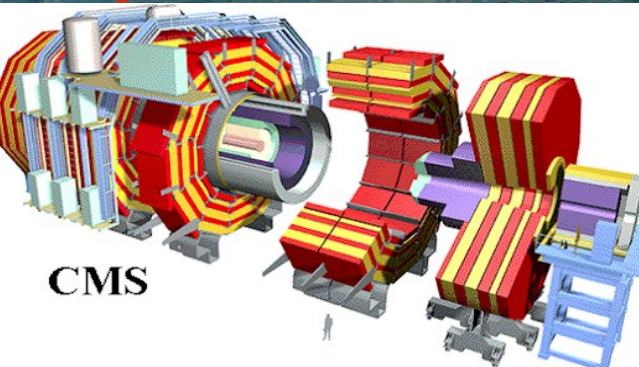

From deep underground...

...to space

Dark matter and ν experiments

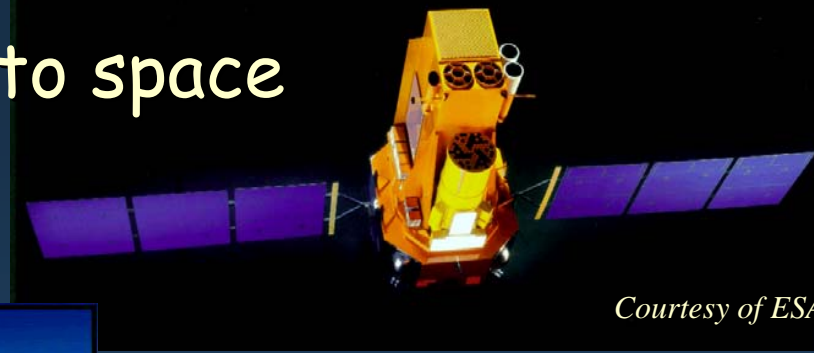
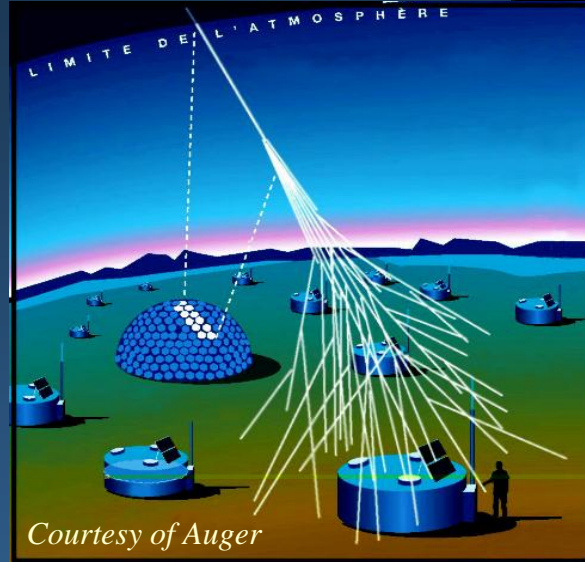
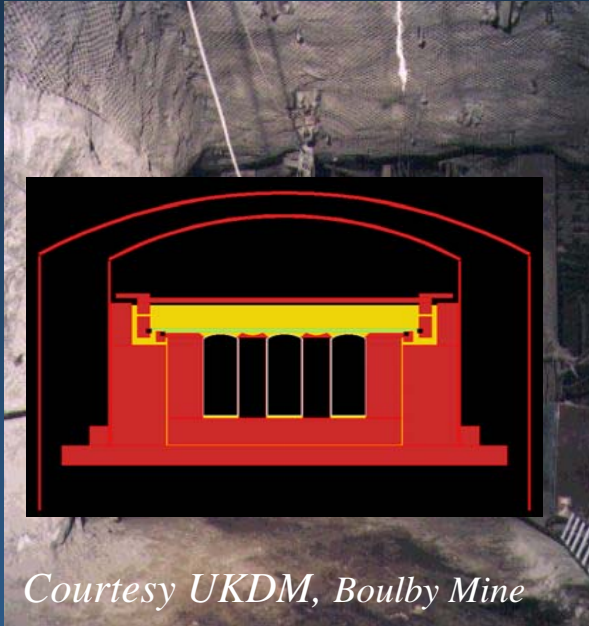

X and γ astronomy,
gravitational waves,
radiation damage to
components etc.

Cosmic ray experiments

Variety of requirements from diverse applications

Physics
from the eV to the PeV scale

Detectors,
spacecrafts and environment

For such experiments software is often **mission critical**
Require **reliability**, rigorous **software engineering standards**

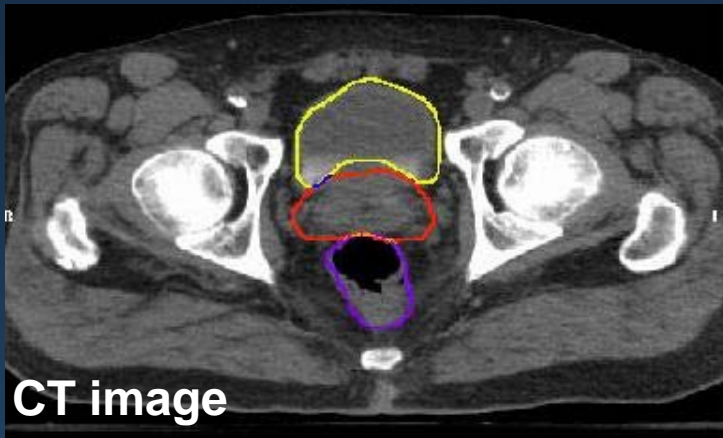

Medical Physics

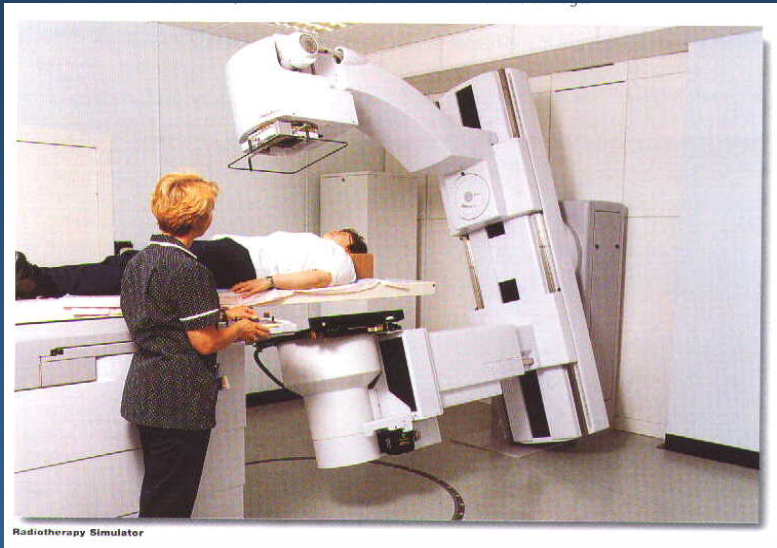
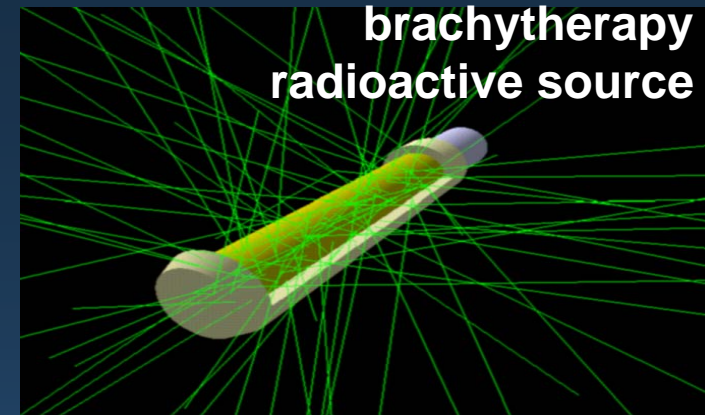

from
hospitals...

...to Mars



- Accurate modelling of radiation sources, devices and human body
- Precision of physics
- Reliability
- Easy configuration and friendly interface
- Speed

...in a fast changing computing environment

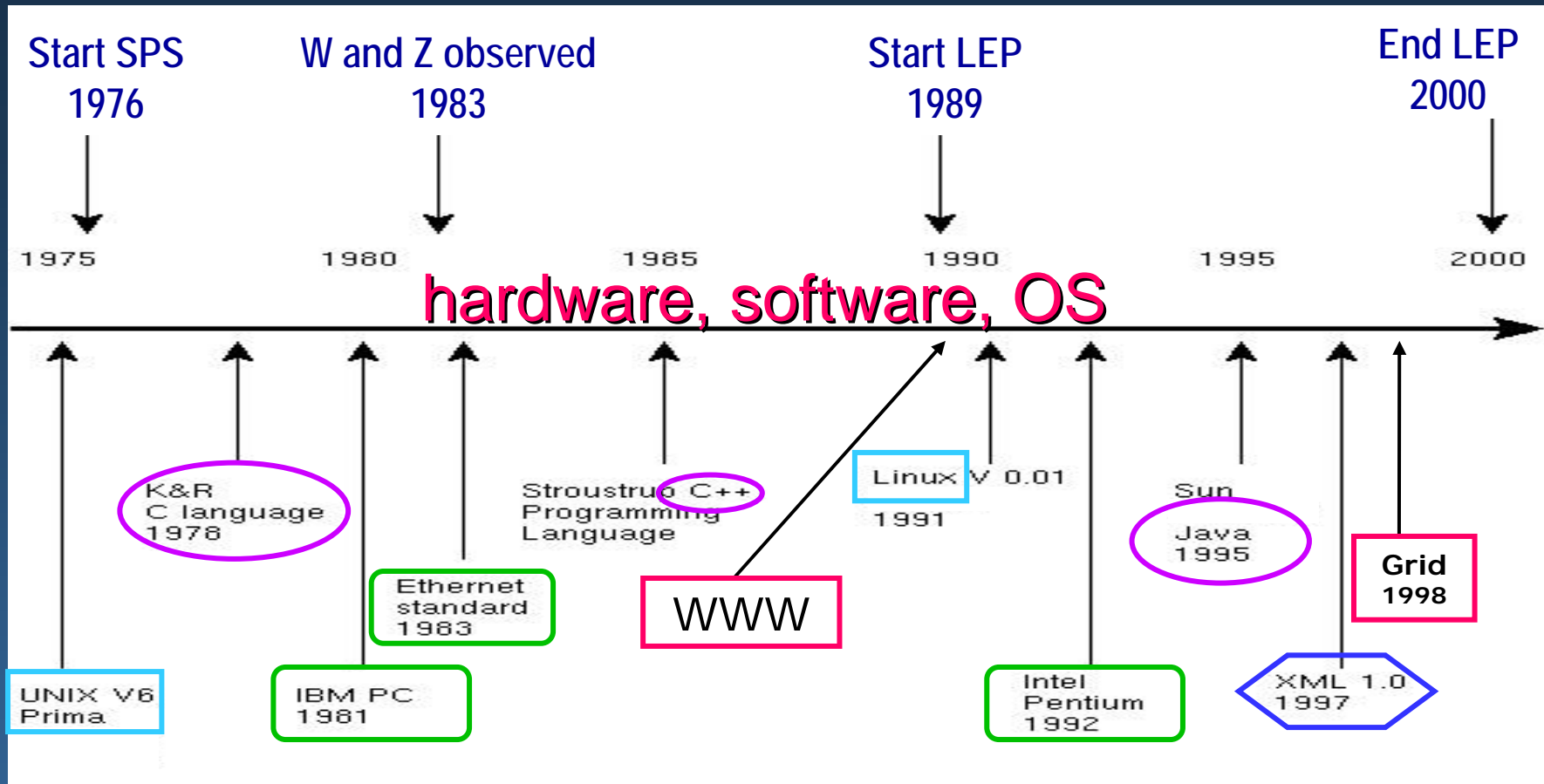

...and don't forget changes of requirements!

Evolution towards greater diversity



we must anticipate changes

OO technology

Openness to **extension** and **evolution**

- new implementations can be added w/o changing the existing code

Robustness and ease of **maintenance**

- **protocols** and well defined dependencies minimize coupling

Strategic vision

Toolkit

A set of compatible components

- each component is **specialised** for a specific functionality
- each component can be **refined** independently to a great detail
- components can be **integrated** at any degree of complexity
- it is easy to provide (and use) **alternative** components
- the user application can be **customised** as needed

The foundation

What characterizes Geant4
Or: the fundamental concepts, which all the rest
is built upon

Physics

From the Minutes of LCB (LHCC Computing Board) meeting on 21 October, 1997:

“It was noted that experiments have requirements for **independent, alternative physics models**. In Geant4 these models, differently from the concept of packages, allow the user to **understand** how the results are produced, and hence improve the **physics validation**. Geant4 is developed with a modular architecture and is the ideal framework where existing components are integrated and new models continue to be developed.”

Software Engineering

plays a fundamental role in Geant4

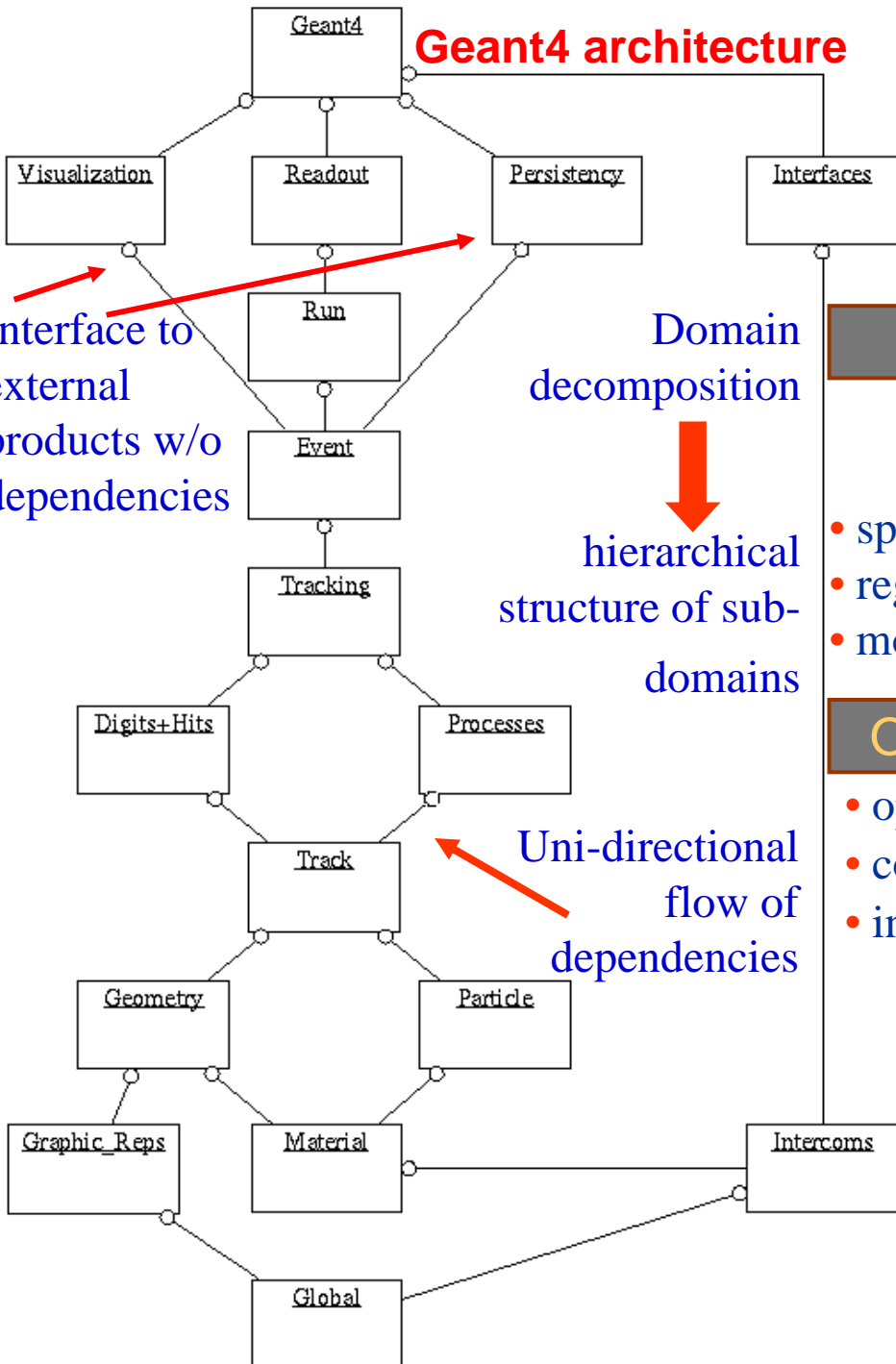

User Requirements

- formally collected
- systematically updated
- PSS-05 standard

Software Process

- spiral iterative approach
- regular assessments and improvements (SPI process)
- monitored following the ISO 15504 model

Object Oriented methods

- OOAD
- use of CASE tools
- openness to extension and evolution
- contribute to the transparency of physics
- interface to external software without dependencies

Quality Assurance

- commercial tools
- code inspections
- automatic checks of coding guidelines
- testing procedures at unit and integration level
- dedicated testing team

Use of Standards

- de jure and de facto

The functionality

What Geant4 can do
How well it does it

The kernel

Run and event

- Multiple events
 - possibility to handle the pile-up
- Multiple runs in the same job
 - with different geometries, materials etc.
- Powerful stacking mechanism
 - three levels by default: handle trigger studies, loopers etc.

Tracking

- Decoupled from physics
 - all processes handled through the same abstract interface
- Independent from particle type
- New physics processes can be added to the toolkit without affecting tracking

Geant4 has only production thresholds, **no tracking cuts**

- all particles are tracked down to zero range
- energy, TOF ... cuts can be defined by the user

Geometry

■ Role

- detailed detector description
- efficient navigation

■ Three conceptual layers

- **Solid**: shape, size
- **LogicalVolume**: material, sensitivity, daughter volumes, etc.
- **PhysicalVolume**: position, rotation

■ One can do fancy things with geometry...

Boolean
operations

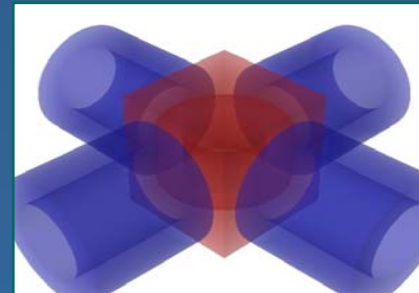

Transparent
solids

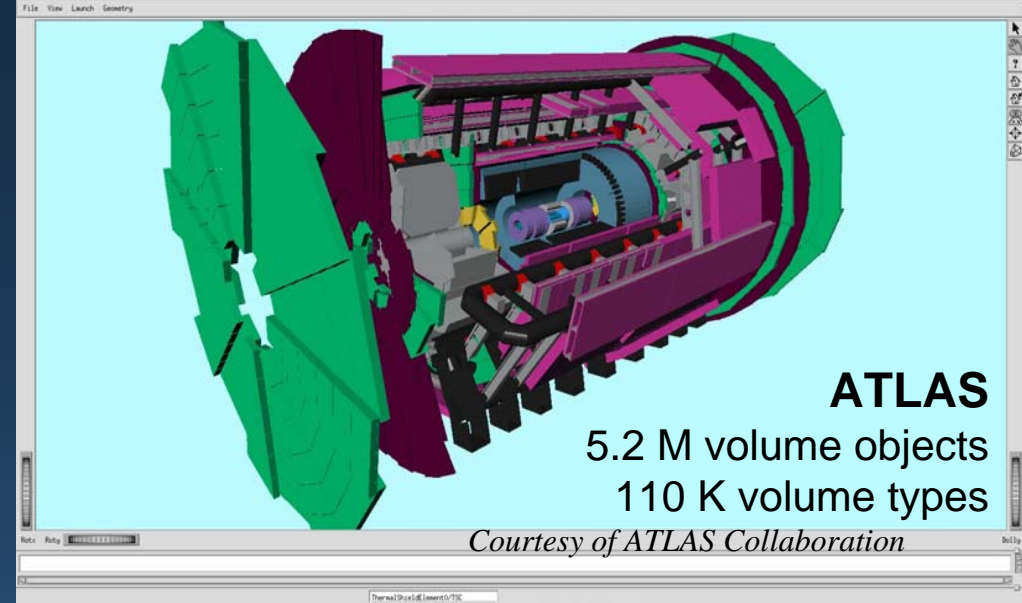

Courtesy of Borexino

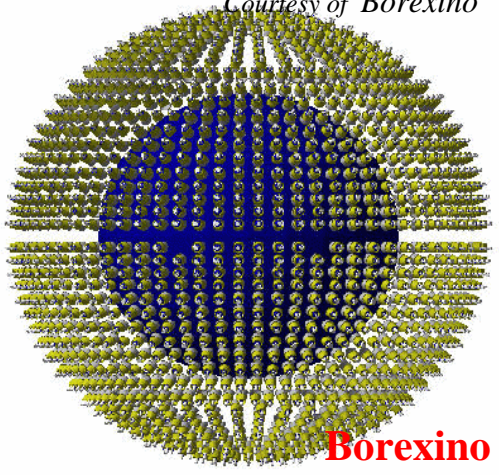

Borexino

Solids

Multiple representations Same abstract interface

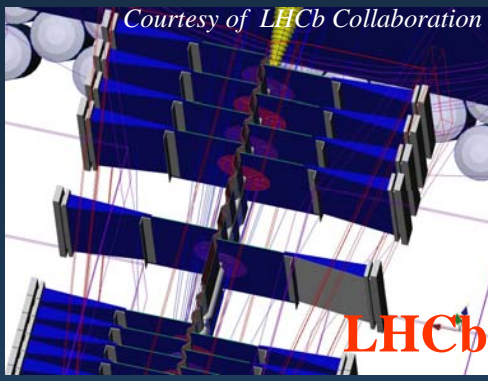

Courtesy of LHCb Collaboration

LHCb

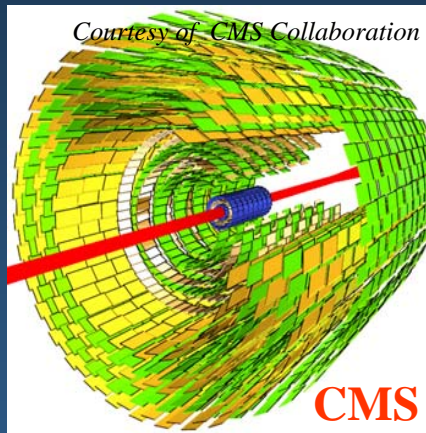

Courtesy of CMS Collaboration

CMS

- **CSG (Constructed Solid Geometries)**
 - simple solids
- **STEP extensions**
 - polyhedra, spheres, cylinders, cones, toroids, etc.
- **BREPS (Boundary REPresented Solids)**
 - volumes defined by boundary surfaces
 - include solids defined by NURBS
(*Non-Uniform Rational B-Splines*)

BaBar

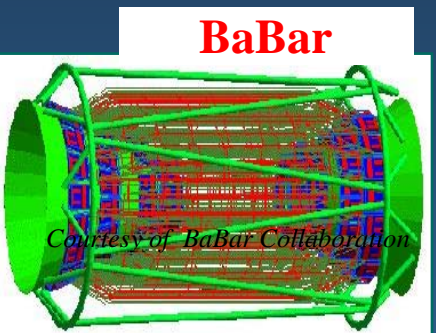

Courtesy of BaBar Collaboration

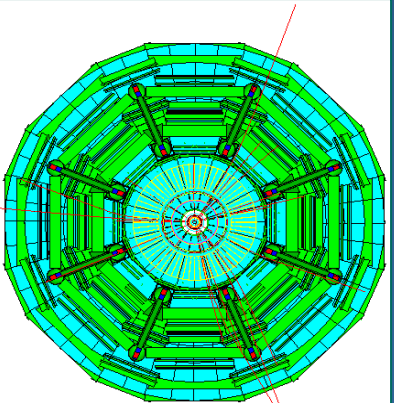

ATLAS

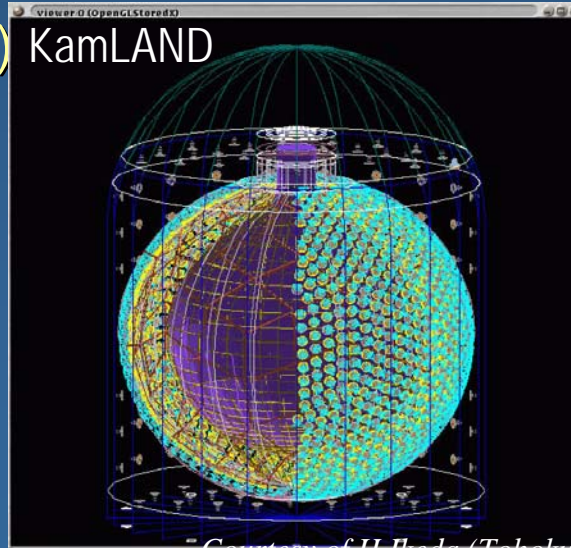

Viewer 0 (OpenGL Stored) KamLAND

Courtesy of H. Ikeda (Tohoku)

CAD exchange: ISO STEP interface

Physical Volumes

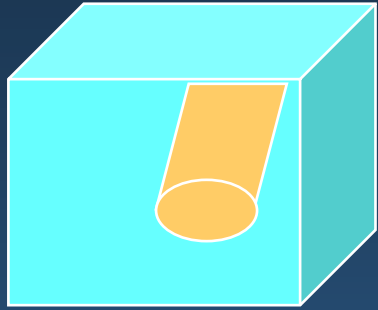

placement

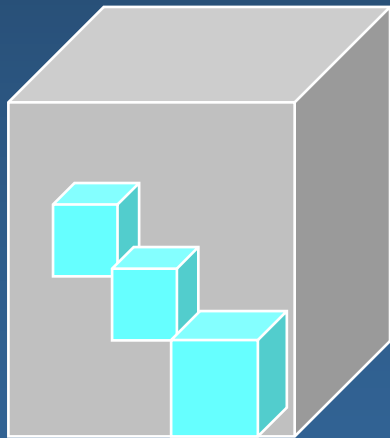
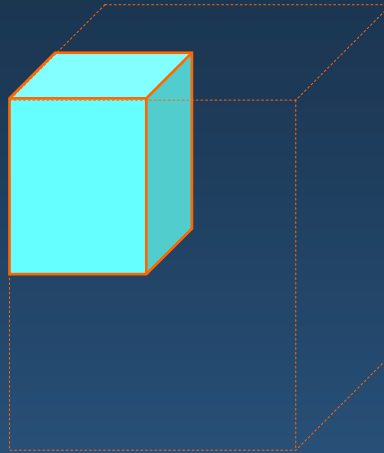

parameterised

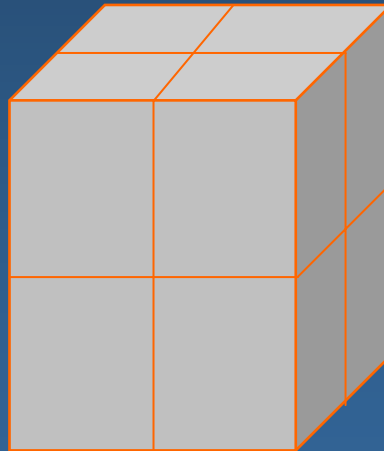

replica

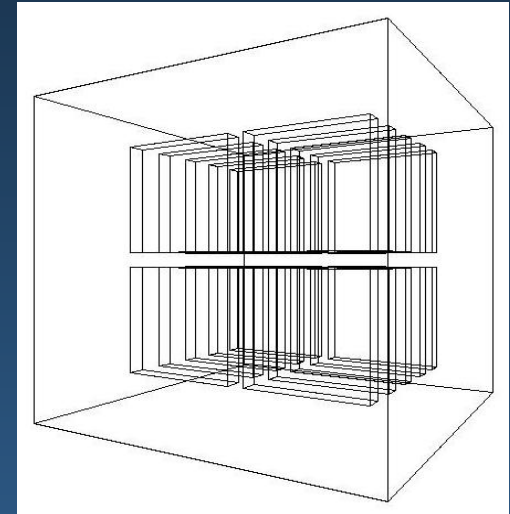

assembled

Versatility to describe
complex geometries

Electric and magnetic fields

of variable non-uniformity
and differentiability

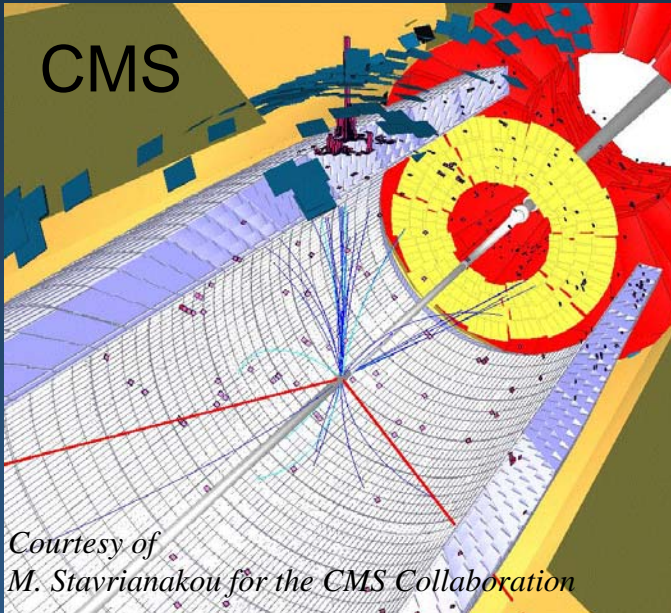

Geant4 field ~ 2 times faster
than FORTRAN/GEANT3

1 GeV proton in the Earth's geomagnetic field

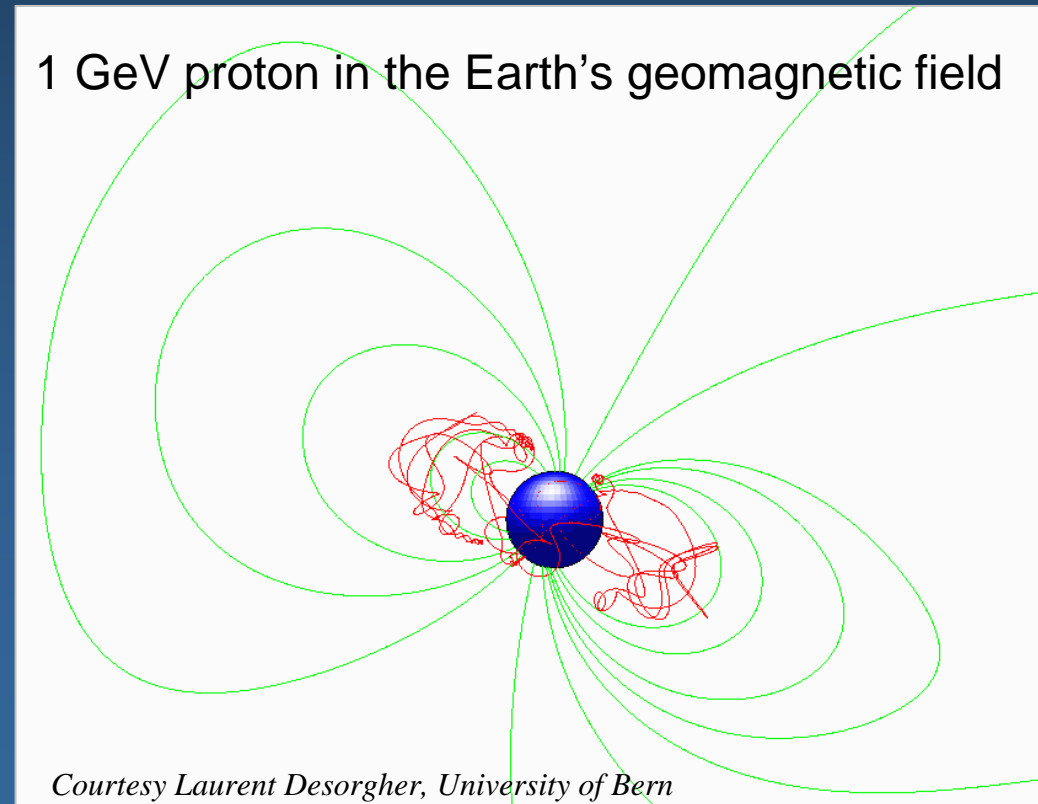

MOKKA

Linear
Collider
Detector

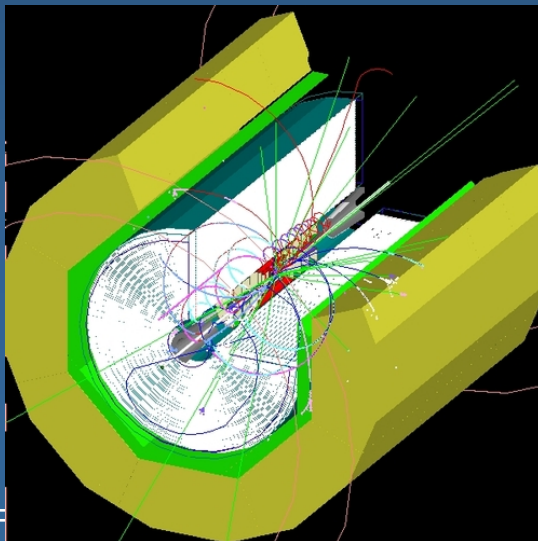

Maria Grazia Pia, INFN

Detector Region

- Concept of region:
 - Set of geometry volumes
 - barrel + end-caps of the calorimeter
 - support structures
 - etc.
 - Or any group of volumes
- A set of cuts in range is associated to a region
 - a different cut for each particle is allowed in a region

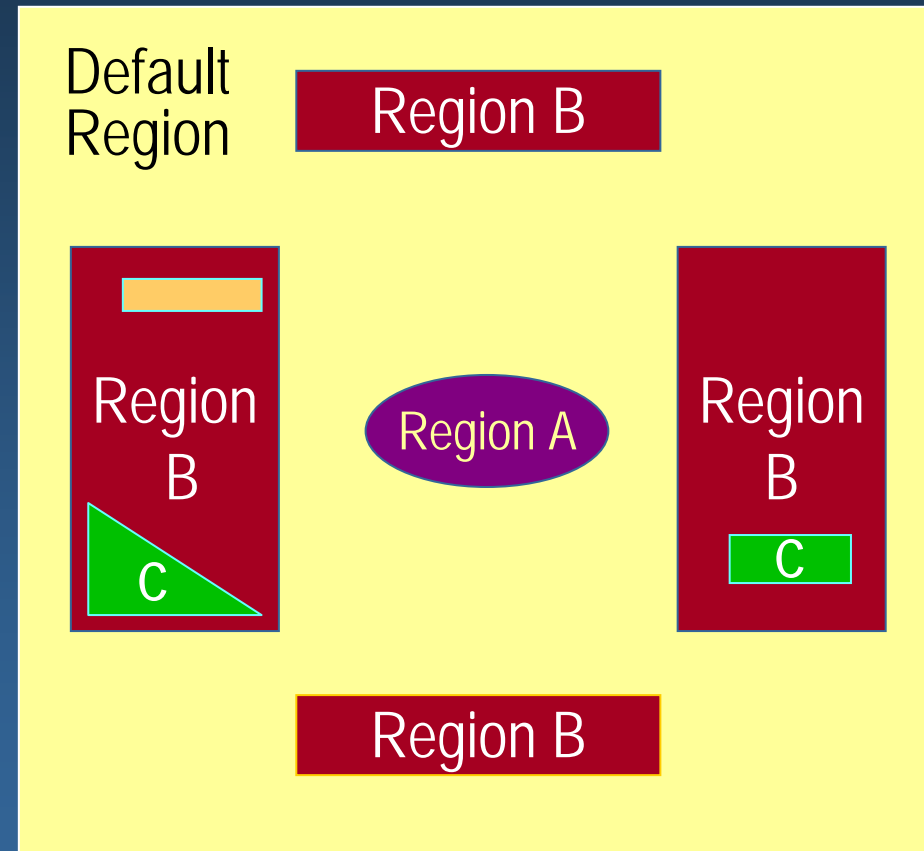

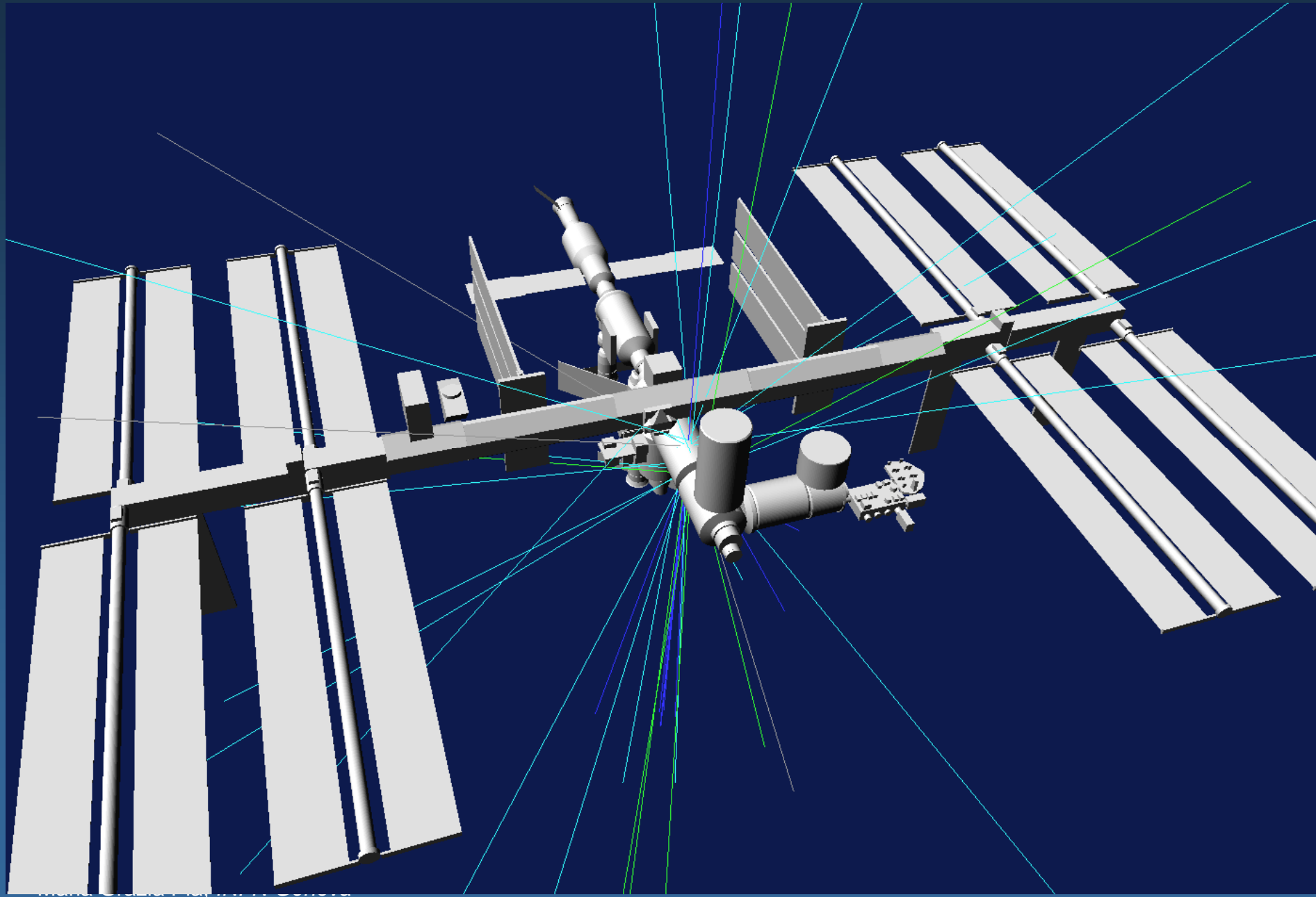

Courtesy T. Ersmark, KTH Stockholm

Not only large scale, complex detectors....

Analytical
breast breast

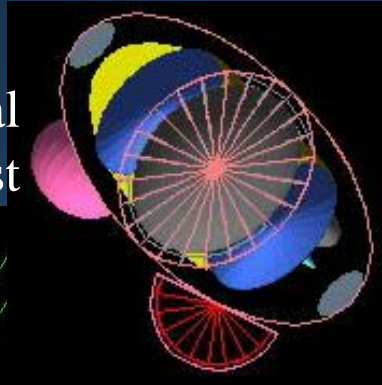

Voxel breast

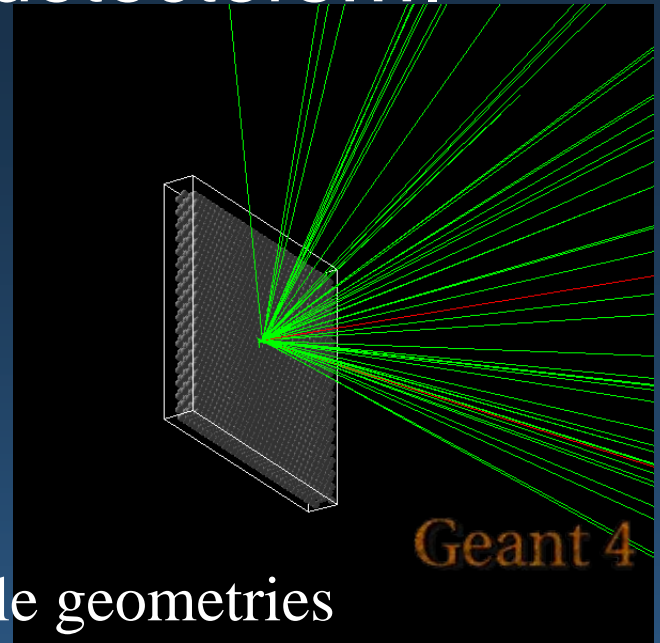
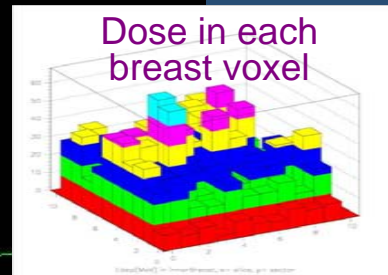

simple geometries

small scale components

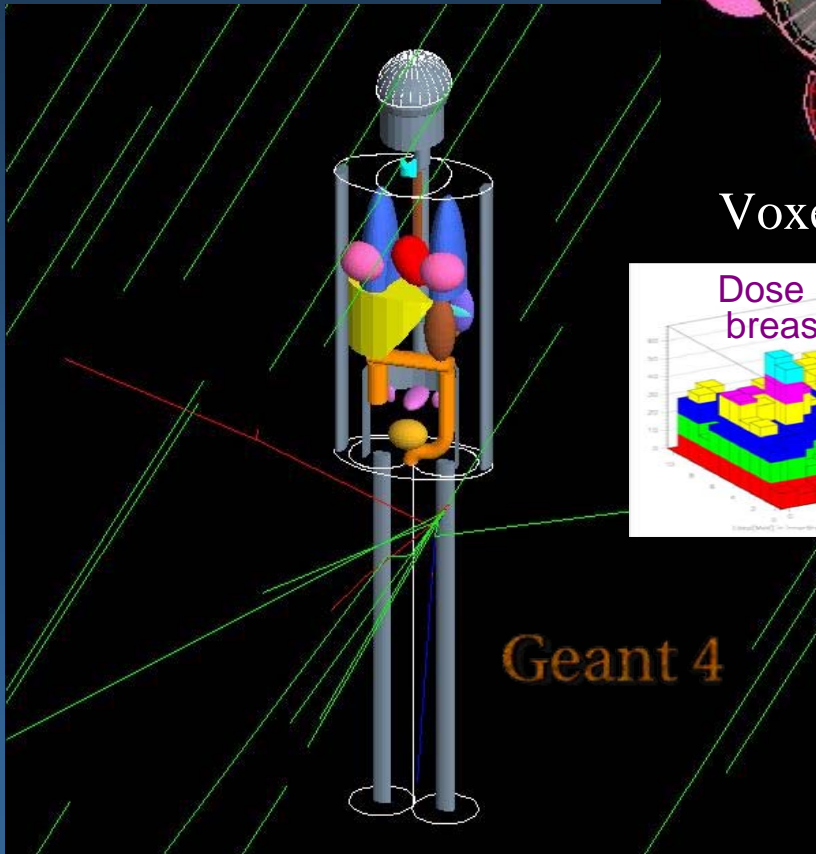

Geant4 anthropomorphic phantoms

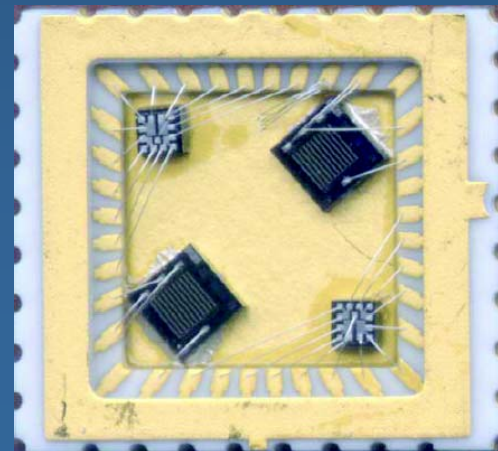

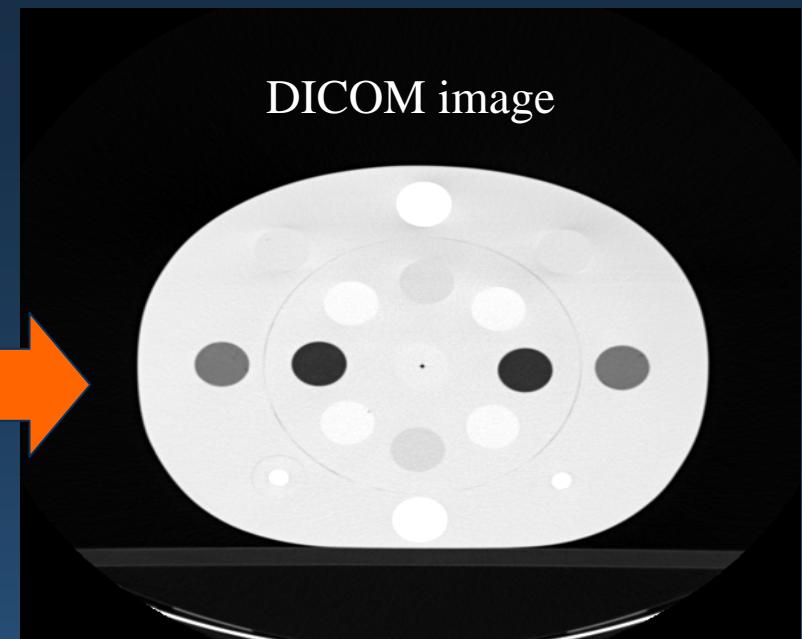
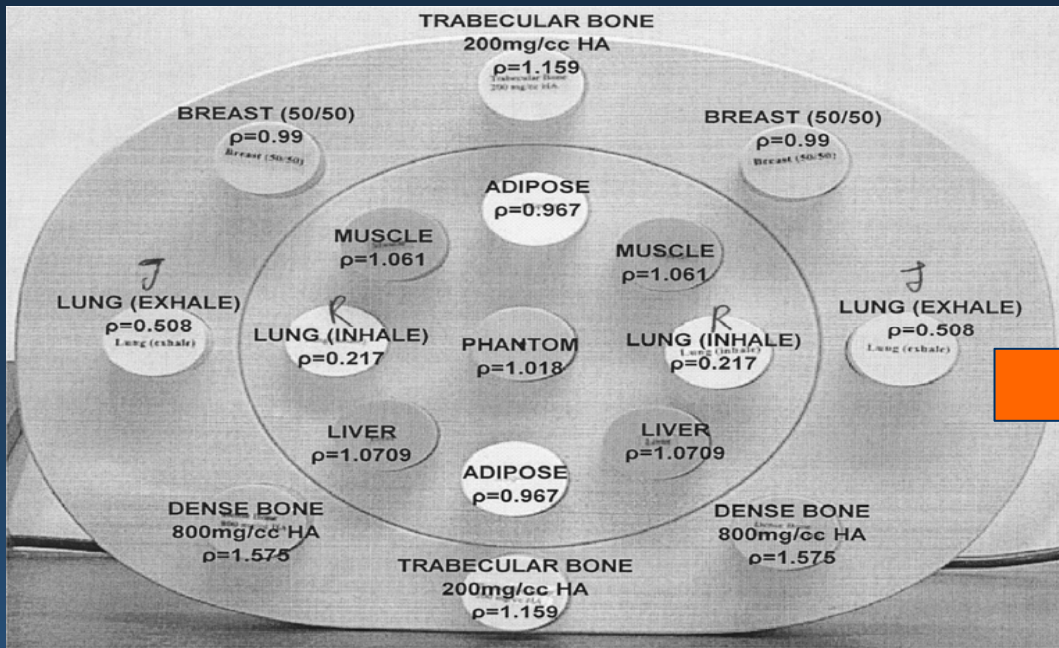

- ◆ Reading image information
- ◆ Transformation of pixel data into densities
- ◆ Association of densities to a list of materials
- ◆ Defining the voxels
 - Geant4 parameterised volumes
 - parameterisation function: material

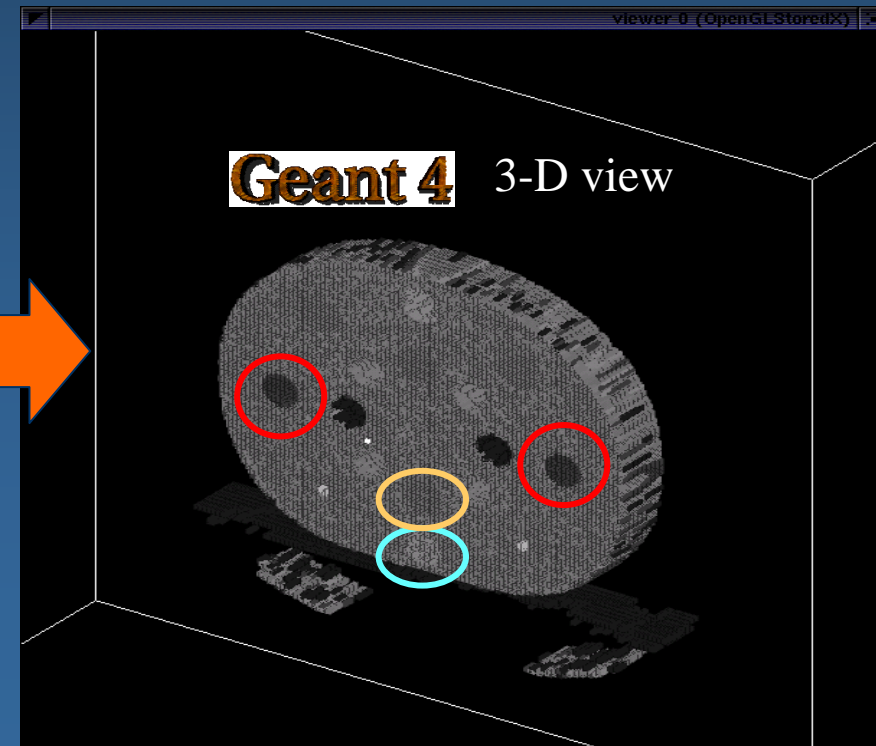

You may also do it wrong...

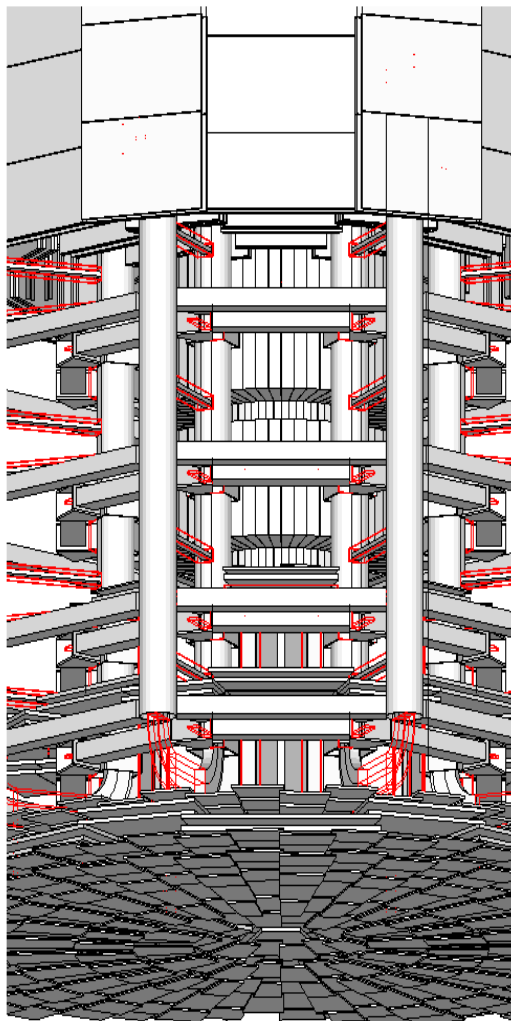

DAVID

Tools to detect badly defined geometries

OLAP

graphical indication of detected overlaps

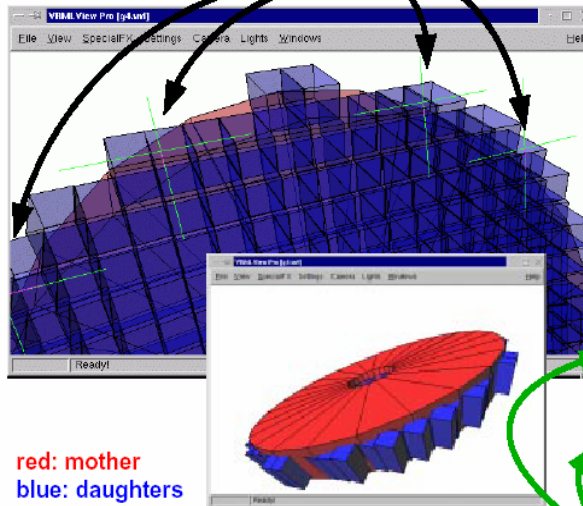

red: mother
blue: daughters

daughters are protruding their mother

Geant4 Macro:

```
/vis/scene/create  
/vis/sceneHandler/create VRML2FILE  
/vis/viewer/create  
/olap/goto ECalEnd  
/olap/grid 7 7 7  
/olap/trigger  
/vis/viewer/update
```

Output:

```
delta=59.3416  
vol 1: point=(560.513,1503.21,-141.4)  
vol 2: point=(560.513,1443.86,-141.4)  
A -> B:  
[0]: ins=[2] PVName=[NewWorld:0] Type=[N] ...  
[1]: ins=[0] PVName=[ECalEndcap:0] Type=[N] ..  
[2]: ins=[1] PVName=[ECalEndcap07:38] Type=[N]  
B -> A:  
[0]: ins=[2] PVName=[NewWorld:0] Type=[N] ...
```

NavigationHistories of points of overlap
(including: info about translation, rotation, solid specs)

Physics

- Abstract interface to physics processes
 - **Tracking independent from physics**
 - Uniform treatment of electromagnetic and hadronic processes
- Distinction between **processes** and **models**
 - multiple models for the same physics process (*complementary/alternative*)
- **Transparency** (supported by *encapsulation* and *polymorphism*)
 - Calculation of cross-sections independent from the way they are accessed (data files, analytical formulae etc.)
 - Calculation of the final state independent from tracking
- Explicit use of units throughout the code
- Open system
 - Users can easily create and use their own models

Data libraries

- Systematic collection and evaluation of experimental data from many sources worldwide
- Databases
 - ENDF/B, JENDL, FENDL, CENDL, ENSDF, JEF, BROND, EFF, MENDL, IRDF, SAID, EPDL, EEDL, EADL, SANDIA, ICRU etc.
- Collaborating distribution centres
 - NEA, LLNL, BNL, KEK, IAEA, IHEP, TRIUMF, FNAL, Helsinki, Durham etc.
- The use of evaluated data is important for the validation of physics results of the experiments

Electromagnetic physics

- electrons and positrons
- γ , X-ray and optical photons
- muons
- charged hadrons
- ions

Comparable to Geant3 already in the α release (1997)

Further extensions (*facilitated by the OO technology*)

■ High energy extensions

- needed for LHC experiments, cosmic ray experiments...

■ Low energy extensions

- fundamental for space and medical applications, dark matter and ν experiments, antimatter spectroscopy etc.

■ Alternative models for the same process

All obeying to the same abstract Process interface  transparent to tracking

Maria Grazia Pia, INFN Genova

energy
loss

- Multiple scattering
- Bremsstrahlung
- Ionisation
- Annihilation
- Photoelectric effect
- Compton scattering
- Rayleigh effect
- γ conversion
- e^+e^- pair production
- Synchrotron radiation
- Transition radiation
- Cherenkov
- Refraction
- Reflection
- Absorption
- Scintillation
- Fluorescence
- Auger

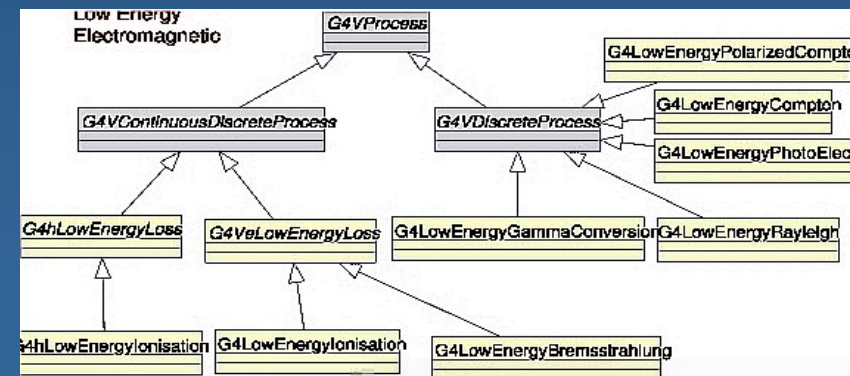

Standard electromagnetic processes

1 keV up to $O(100 \text{ TeV})$

- Multiple scattering
 - model based on Lewis theory
 - computes mean free path length and lateral displacement
- New energy loss algorithm
 - optimises the generation of δ rays near boundaries
- Variety of models for ionisation and energy loss
 - including PhotoAbsorption Interaction model (for thin layers)
- Many optimised features
 - Secondaries produced only when needed
 - Sub-threshold production

Multiple scattering

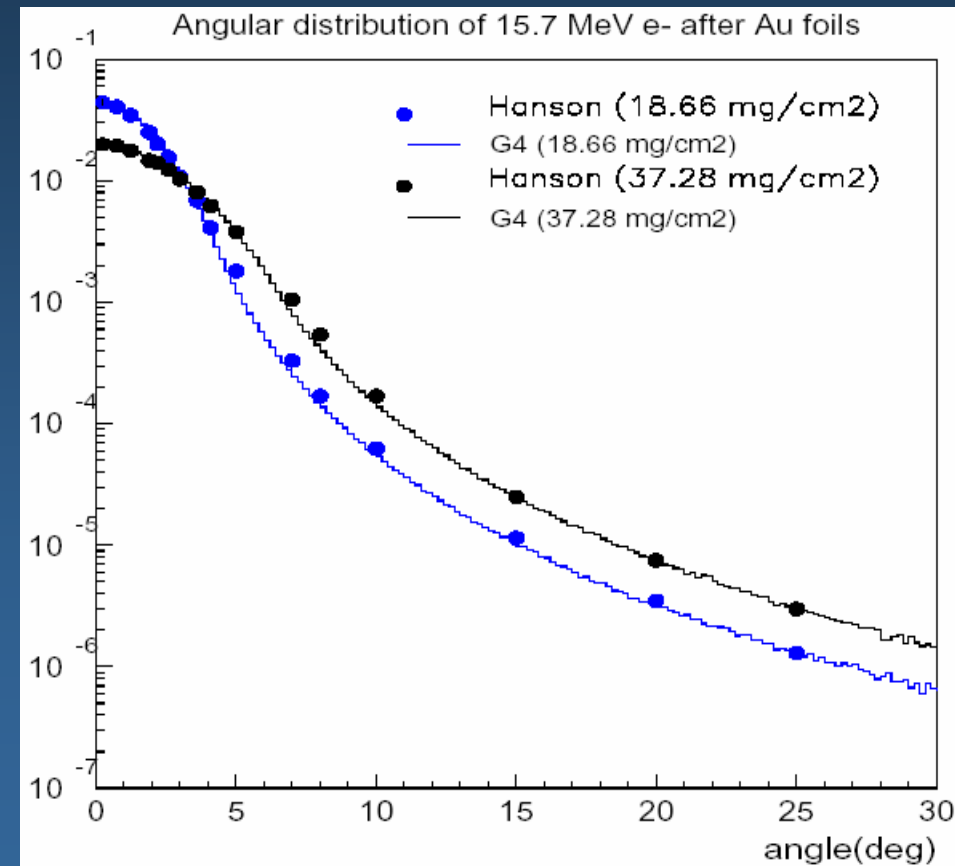

MuScat (TRIUMF E875)

- Multiple scattering of muons of momenta up to 200 MeV/c
- Important for the optimal design of a cooling channel for a ν factory or μ collider

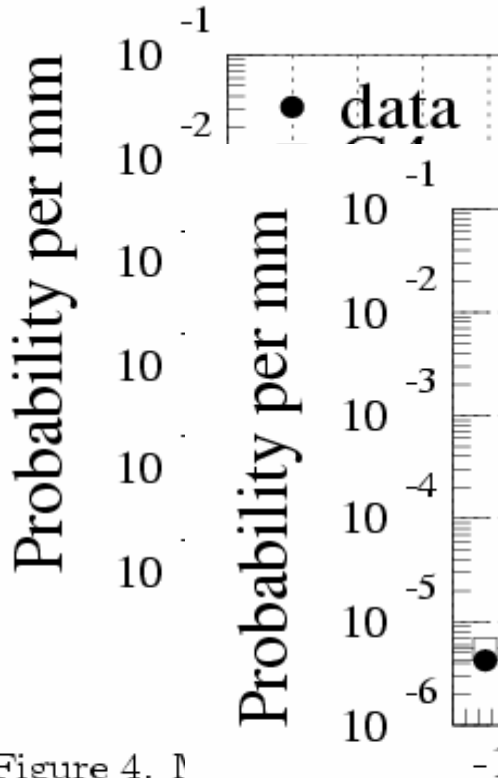

Figure 4. Probability per mm vs Position. mm. The plot shows a distribution centered at 0 mm. The y-axis is logarithmic, ranging from 10⁻⁶ to 10⁻¹. The x-axis is linear, ranging from -100 to 100 mm. Data points are shown as black circles with error bars.

Probability per mm

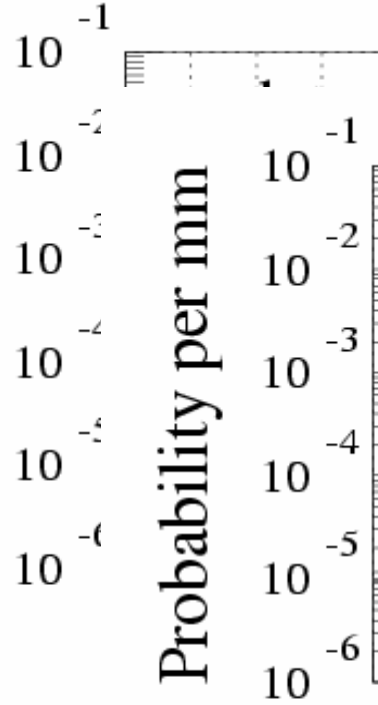

Figure 5. The Sci-Fi plane when no target is present.

Figure 6. The Sci-Fi plane with a target.

Probability per mm

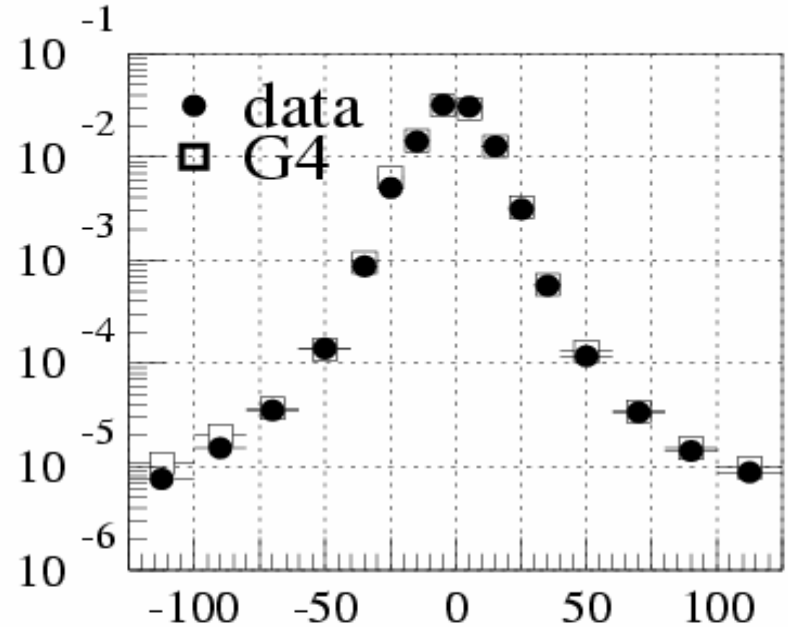
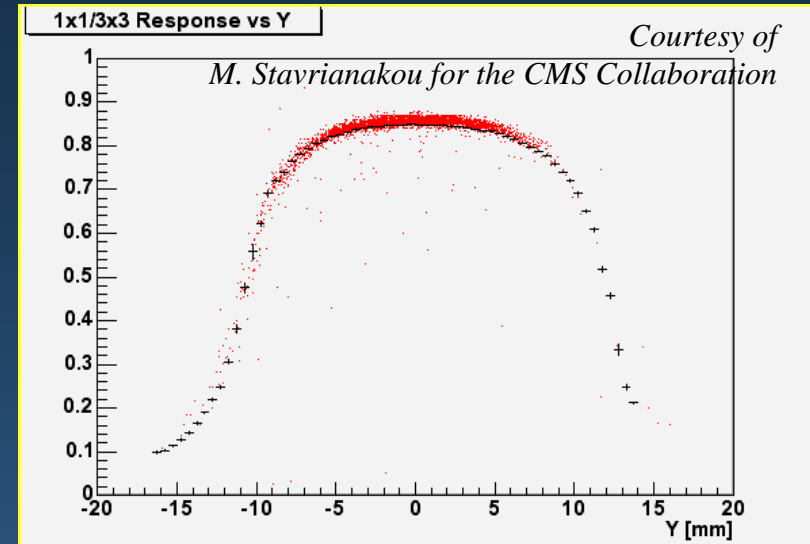
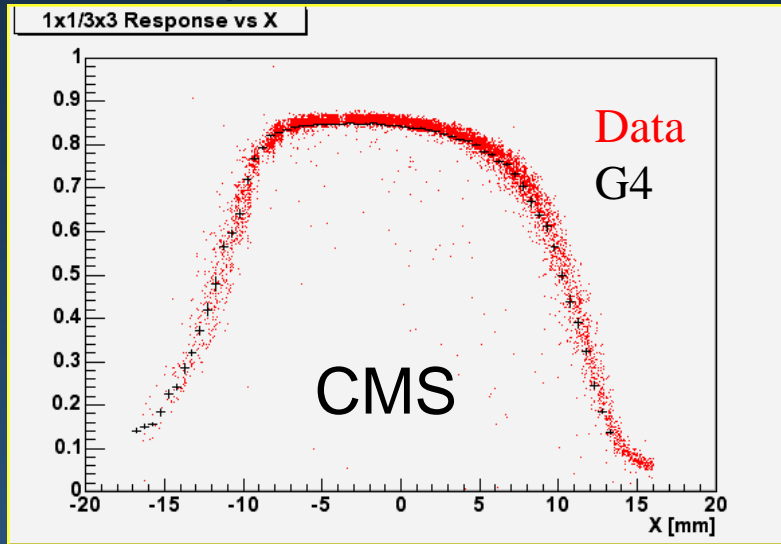

Figure 7. The measured arrival position distributions with a 3.0 mm liquid hydrogen target.

Figure 8. The measured and simulated arrival position distributions with a 150 mm liquid hydrogen target.

Calorimetry

Single crystal containment: E_{1x1}/E_{3x3} versus position



Tracking

Geant4 Standard
Electromagnetic
Physics

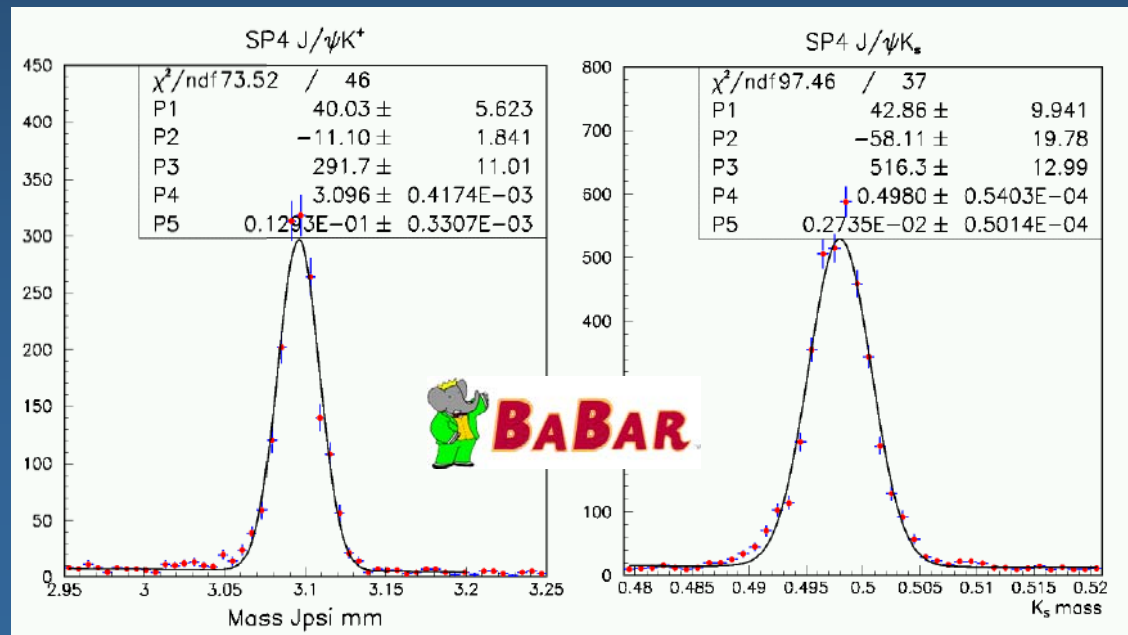

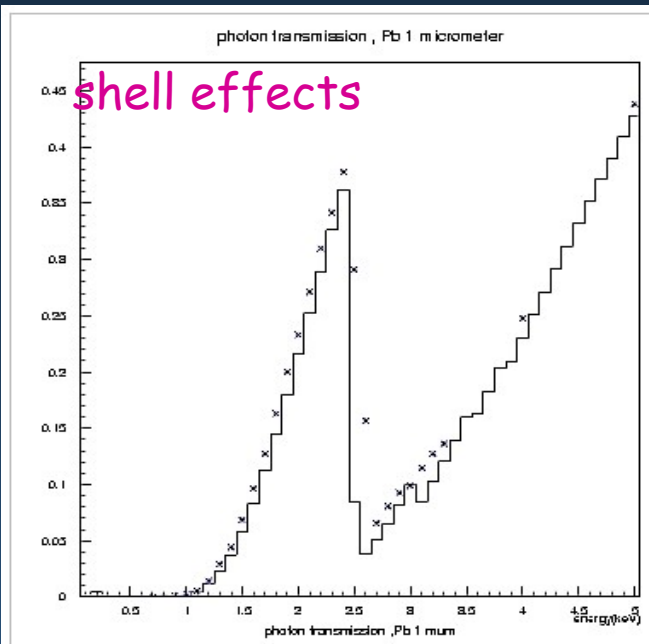

Geant 4

e, γ down to 250/100 eV
 EGS4, ITS to 1 keV
 Geant3 to 10 keV

- ① Based on EPDL97, EEDL and EADL evaluated data libraries
- ② Based on Penelope analytical models

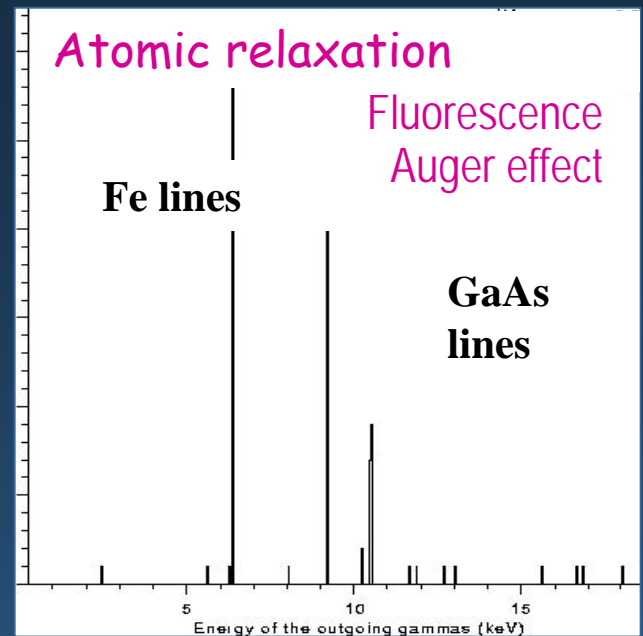

Hadron and ion models based on Ziegler and ICRU data and parameterisations

Barkas effect (charge dependence) models for **negative hadrons**

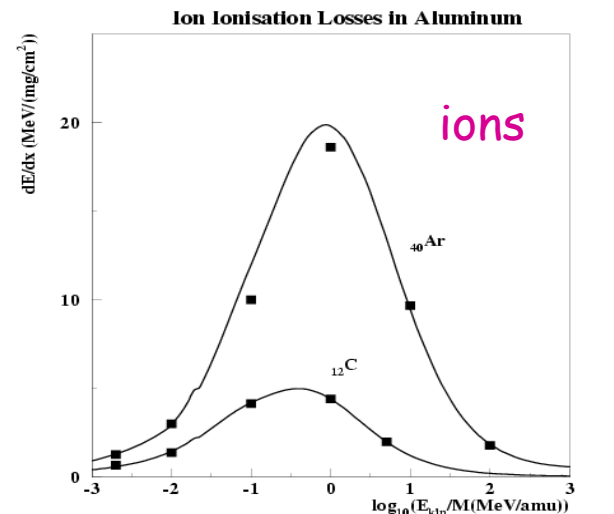
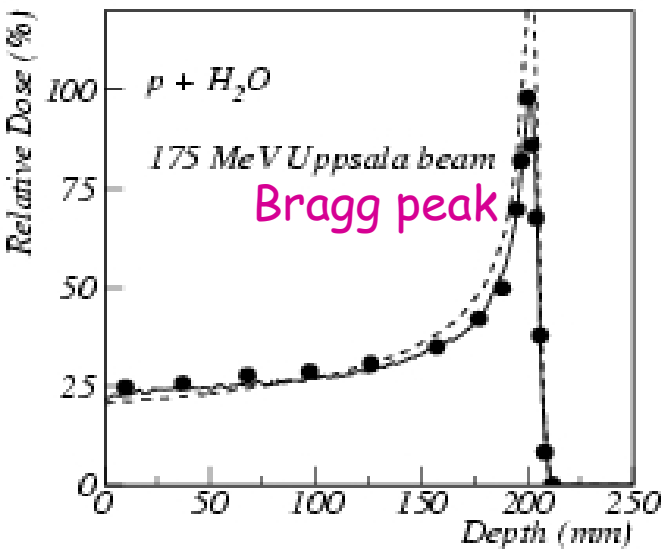
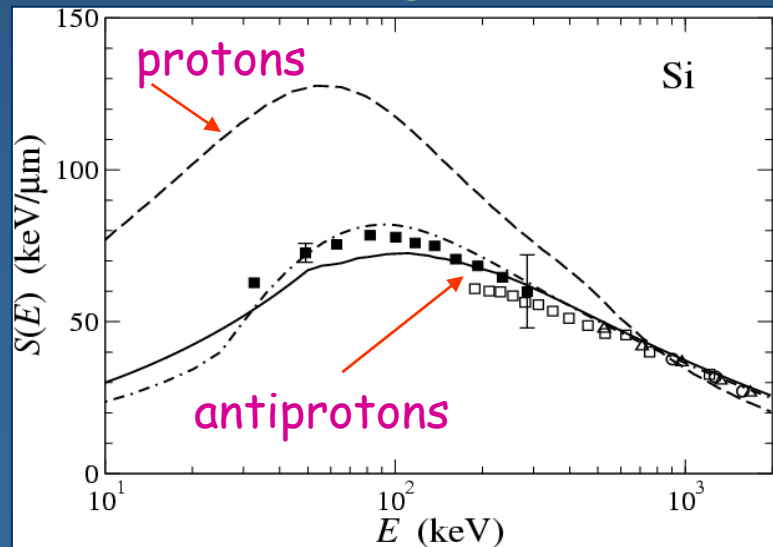

Figure 9: Ion electronic stopping power in aluminum. Points - the best fit on the data from Ref.[12], solid line - GEANT4 parameterisation. The accuracy of the data is about 5%.



“Comparison of Geant4 electromagnetic physics models against the NIST reference data”

IEEE Transactions on Nuclear Science, vol. 52 (4), pp. 910-918, 2005

Geant4 electromagnetic physics models are accurate

Compatible with NIST data within NIST accuracy (LowE p-value > 0.9)

Mass attenuation coefficient in Fe

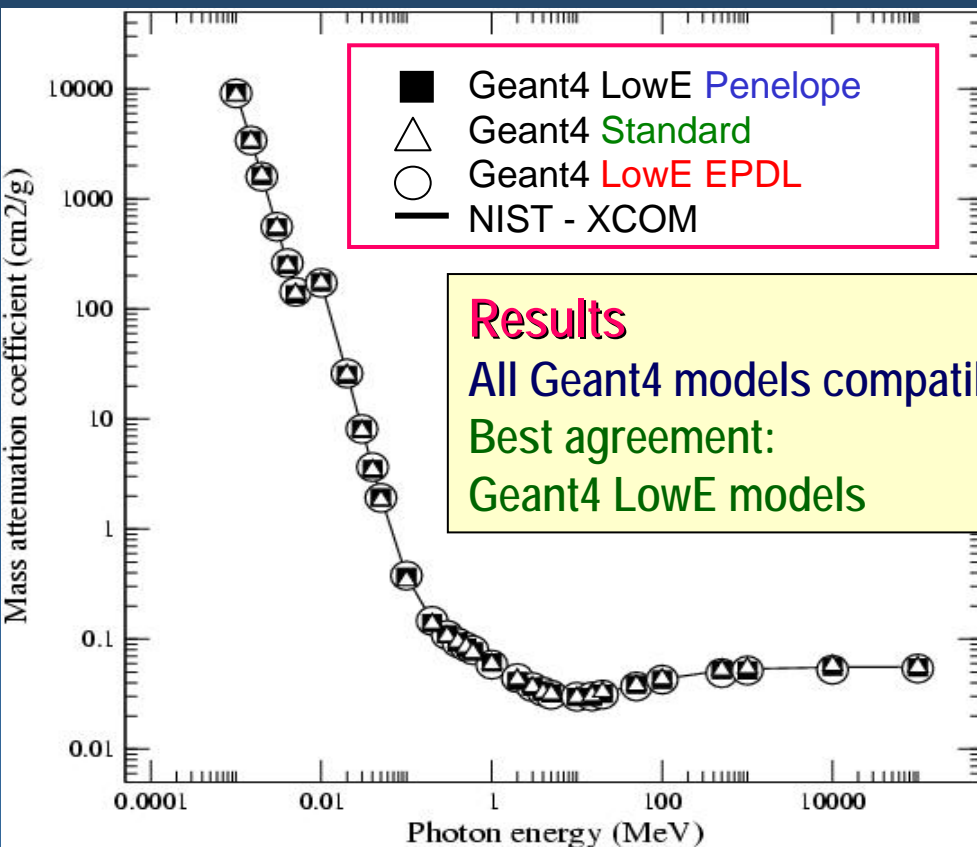

Results

All Geant4 models compatible with NIST

Best agreement:

Geant4 LowE models

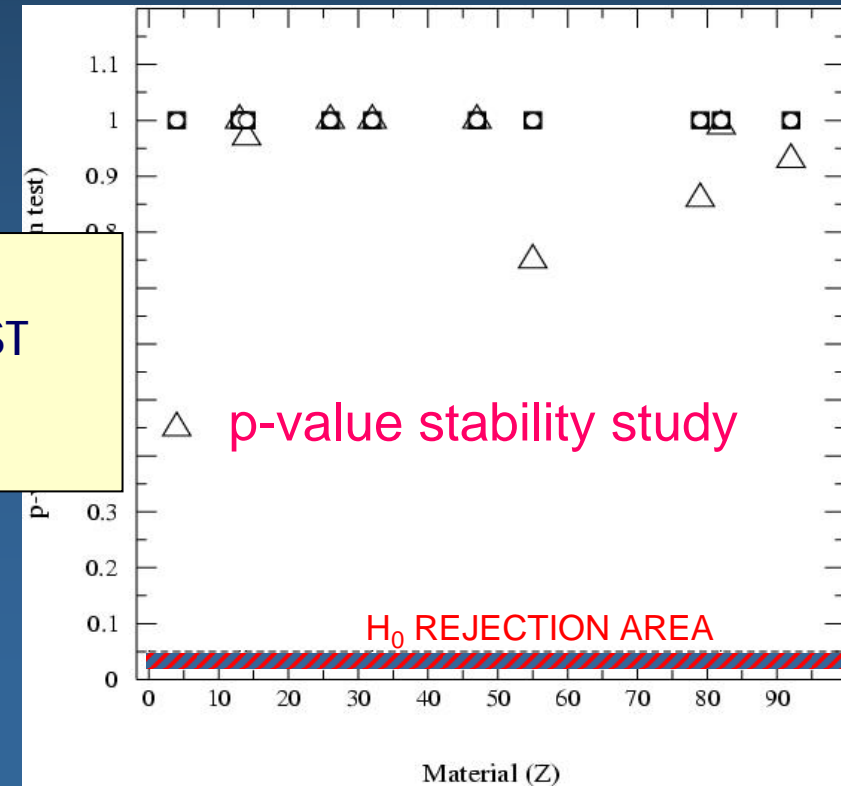

A medical accelerator for IMRT

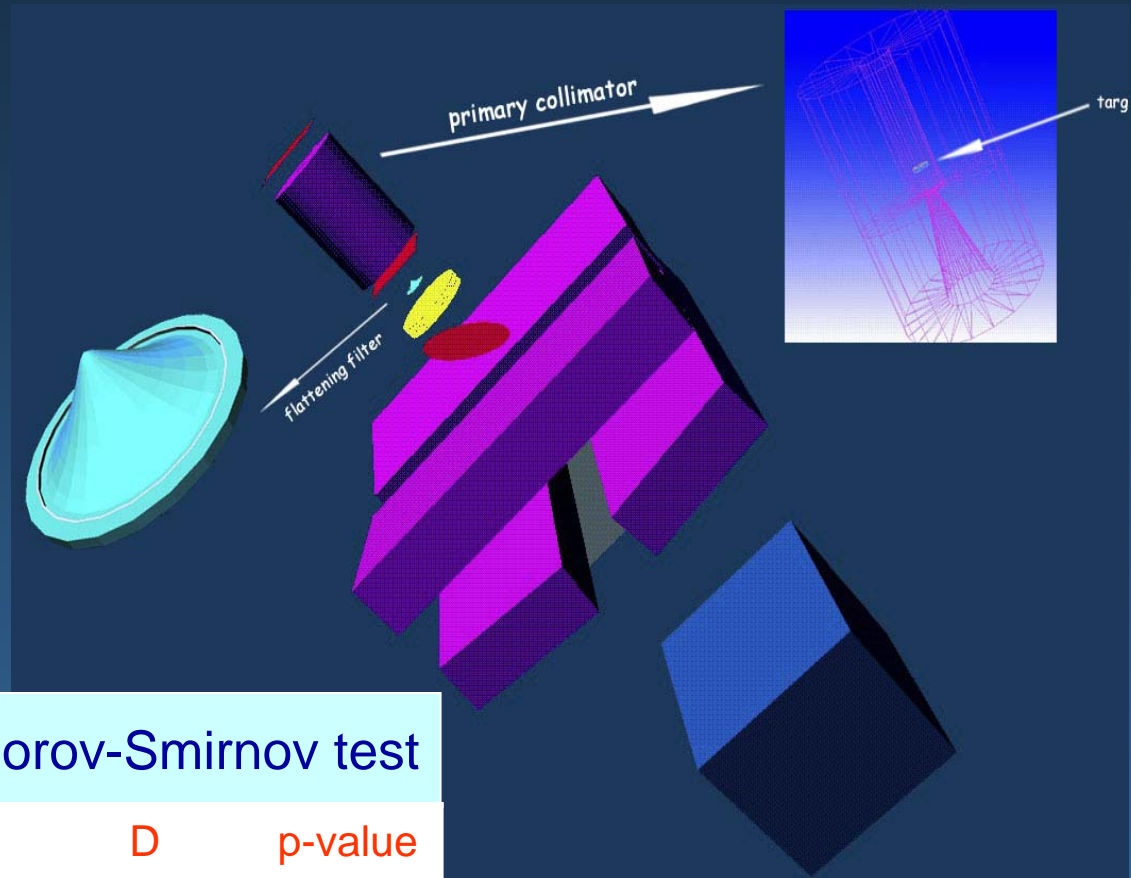
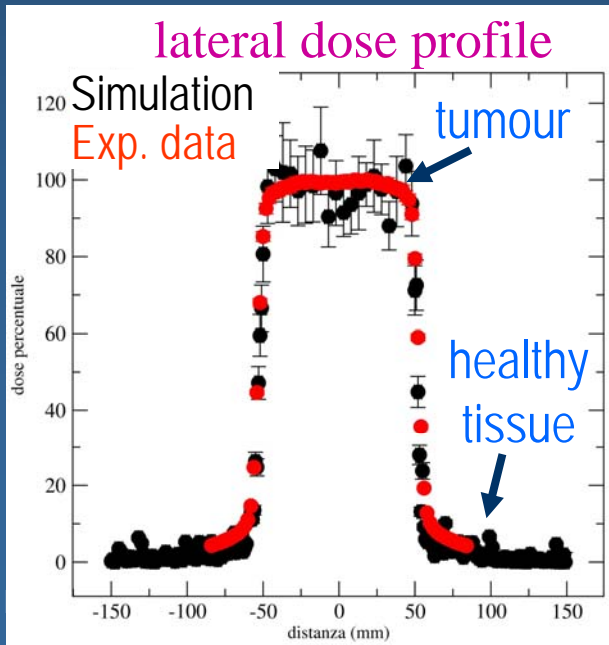
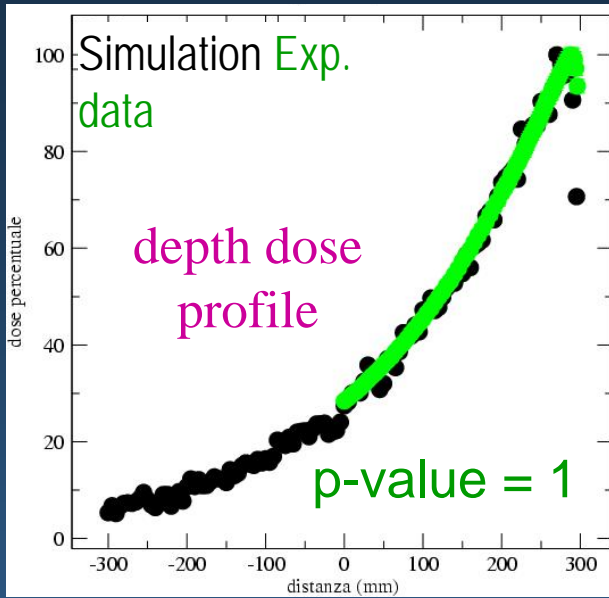

Kolmogorov-Smirnov test

range	D	p-value
-84 ÷ -60 mm	0.385	0.23
-59 ÷ -48 mm	0.27	0.90
-47 ÷ 47 mm	0.43	0.19
48 ÷ 59 mm	0.30	0.82
60 ÷ 84 mm	0.40	0.10



Dosimetry

Endocavitary brachytherapy

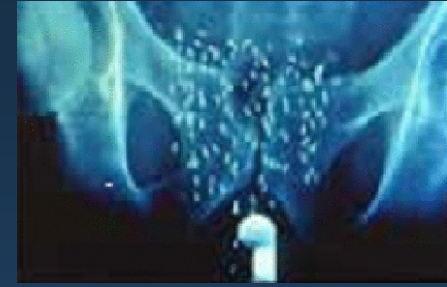

MicroSelectron-HDR source

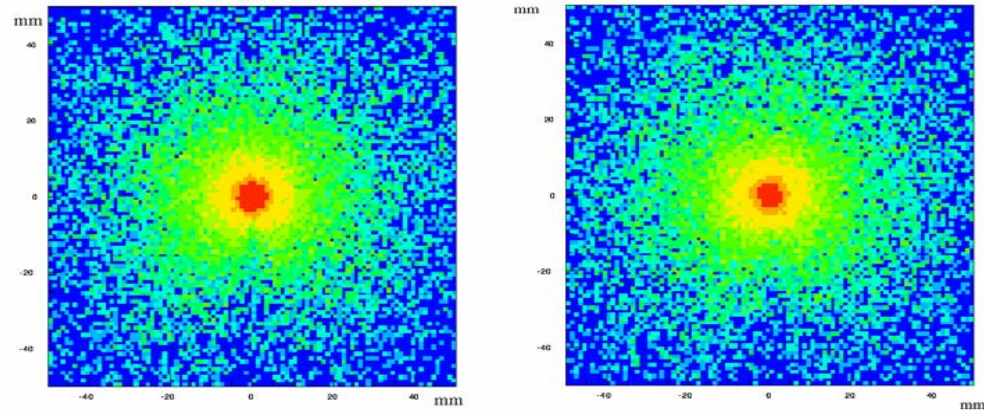

Dosimetry

Interstitial brachytherapy

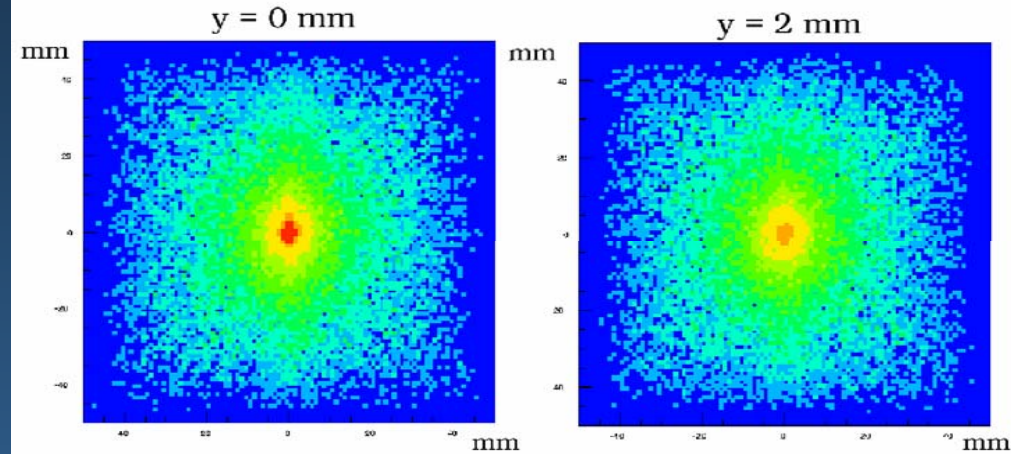

Dosimetry

Superficial brachytherapy

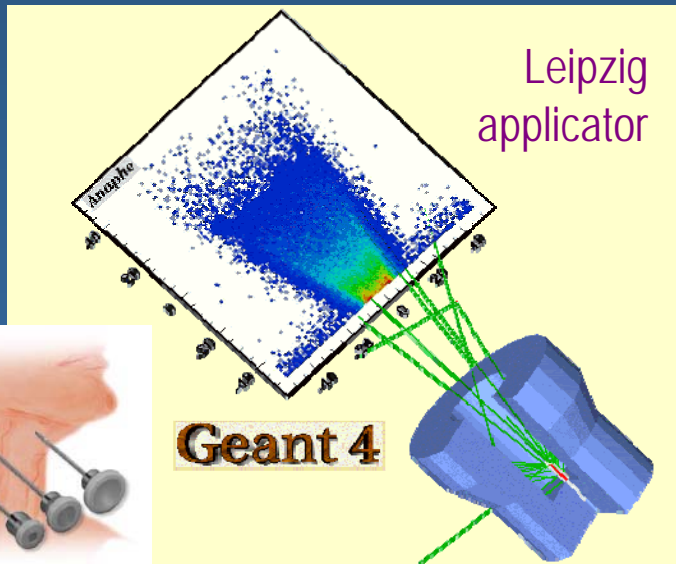

Bebig Iseeed I-125 source

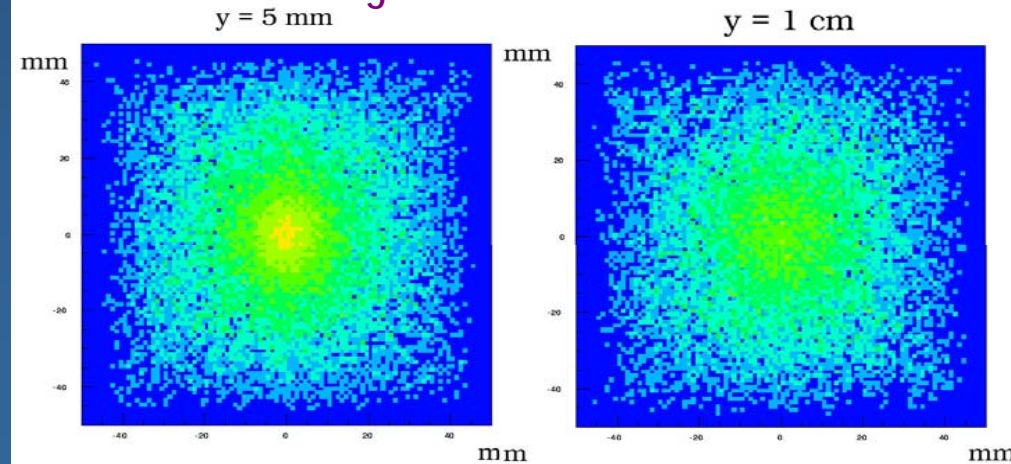

Real hadrontherapy beam line



CATANA hadrontherapy

Paper to be submitted to
IEEE Trans. Nucl. Sci., Dec. 2006

	p-value		
	CvM	KS	AD
Left branch	0.977		
Right branch		0.985	
Whole curve			0.994

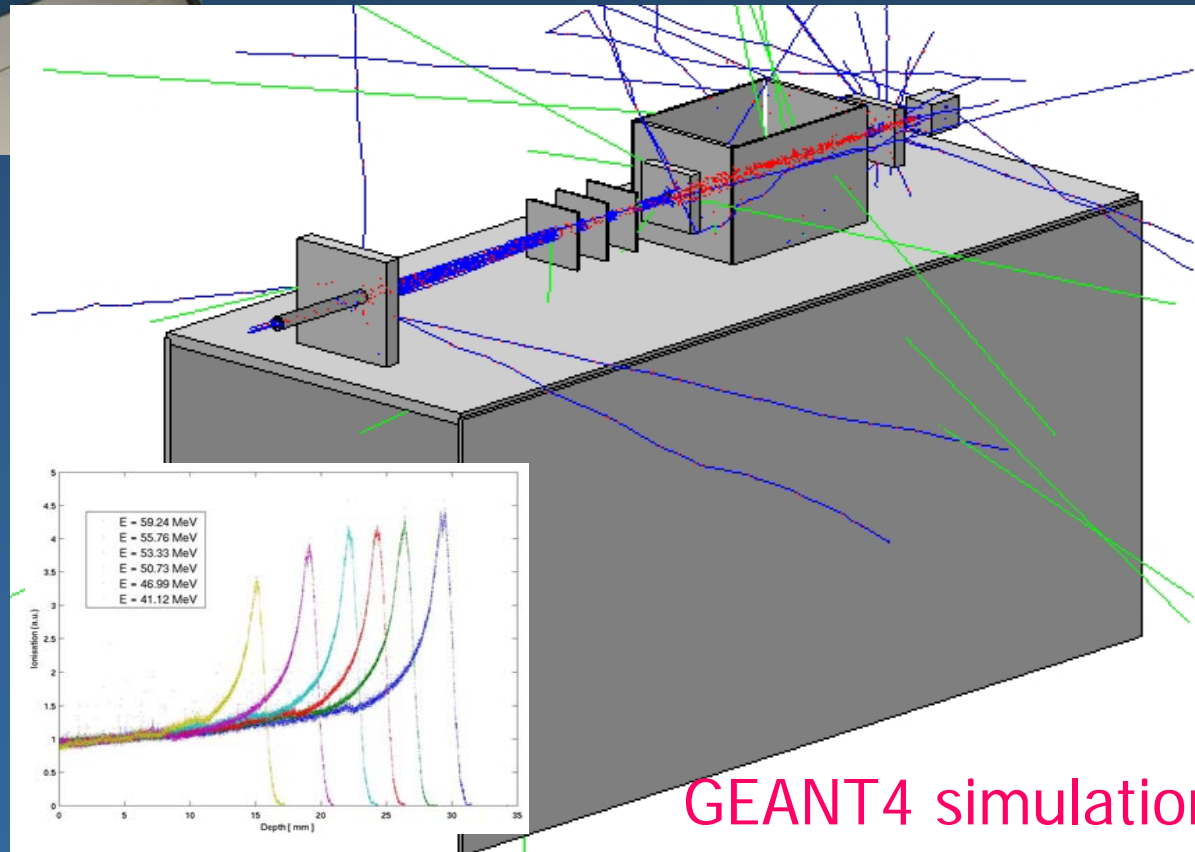
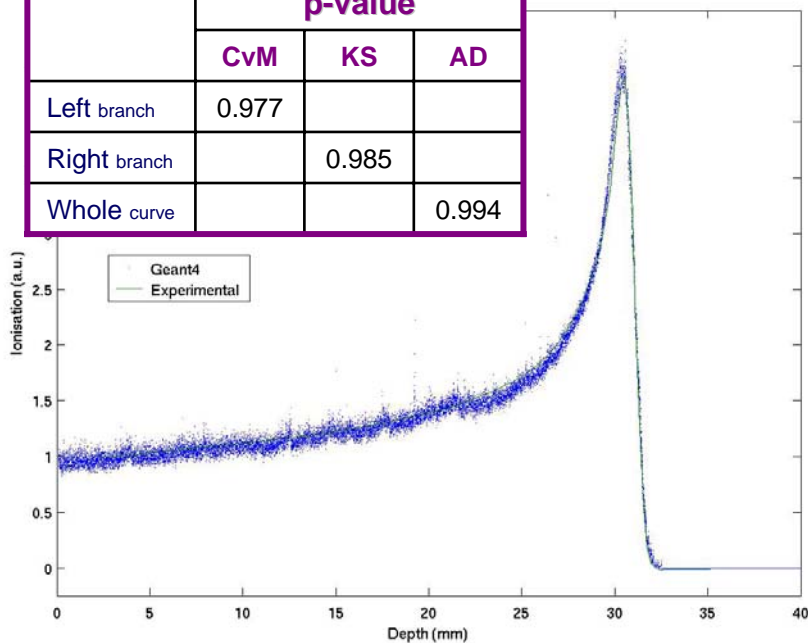

GEANT4 simulation

Dosimetry in interplanetary missions



Aurora Programme

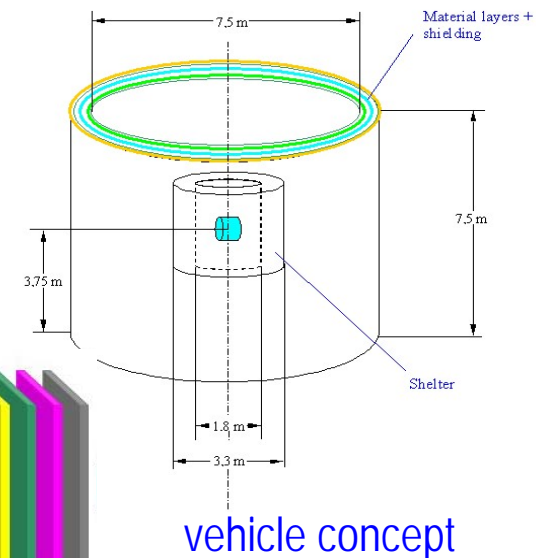

vehicle concept

Dose in the phantom

GCR - EM Physics - 10 cm polyethylene

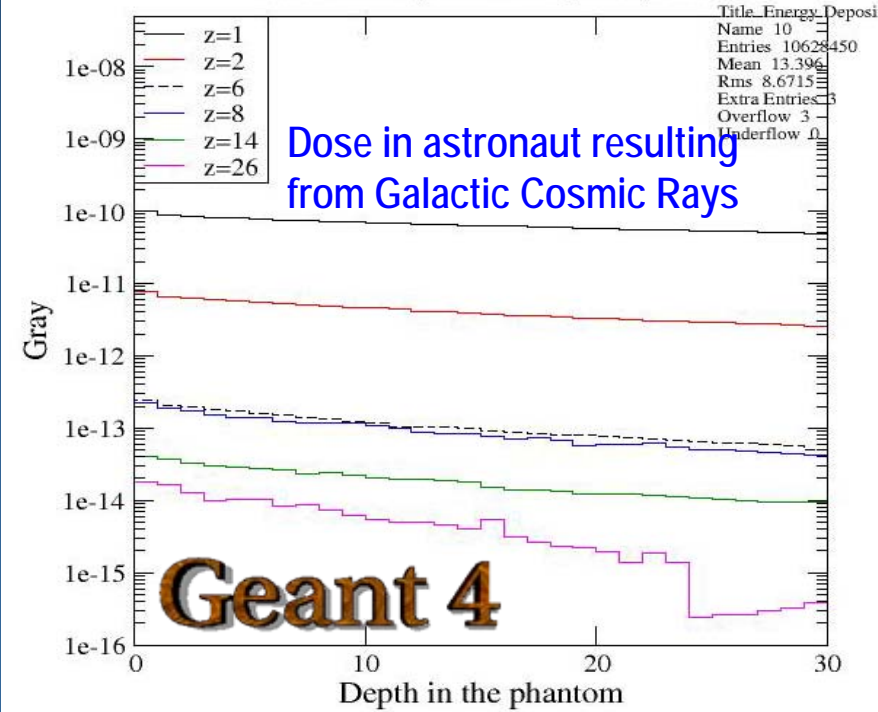

Dose in astronaut resulting from Galactic Cosmic Rays



Maria Grazia Pia, INFN Genova

Cosmic rays,
jovian electrons

Solar system explorations

Study of the elemental composition of planets, asteroids and moons → clues to solar system formation

X-ray fluorescence

Arising from the solar X-ray flux, sufficient, for the inner planets, to significant fluorescence fluxes to an orbiter

PIXE

Significant only during particle events, during which it can exceed XRF

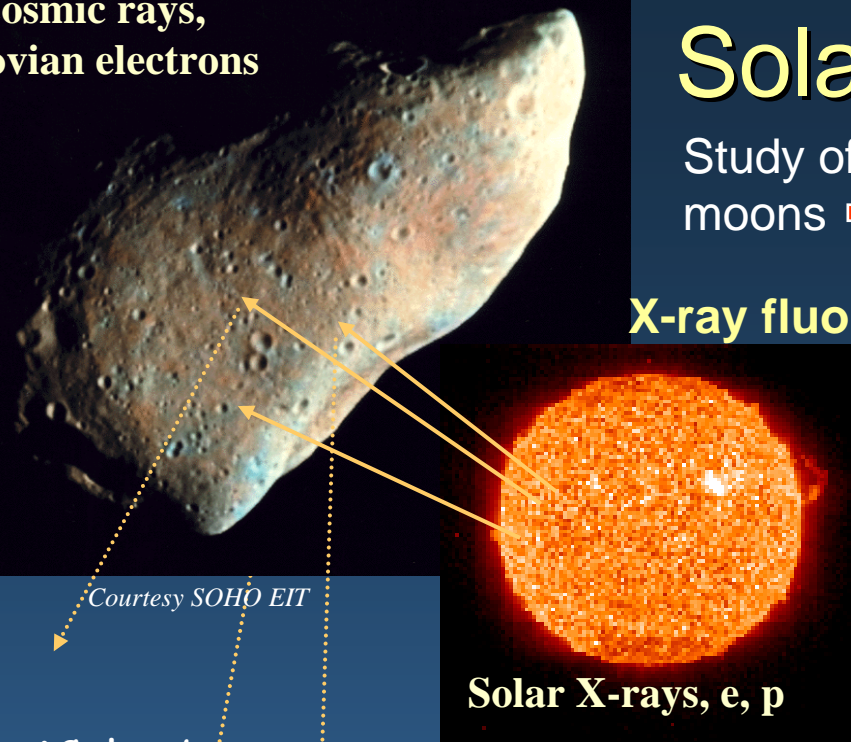

BepiColombo
ESA cornerstone mission to Mercury

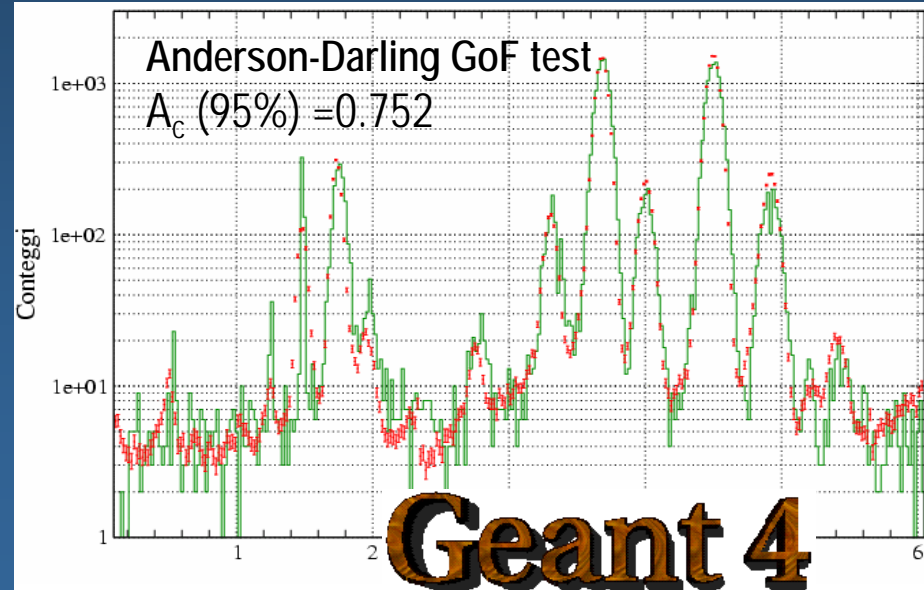
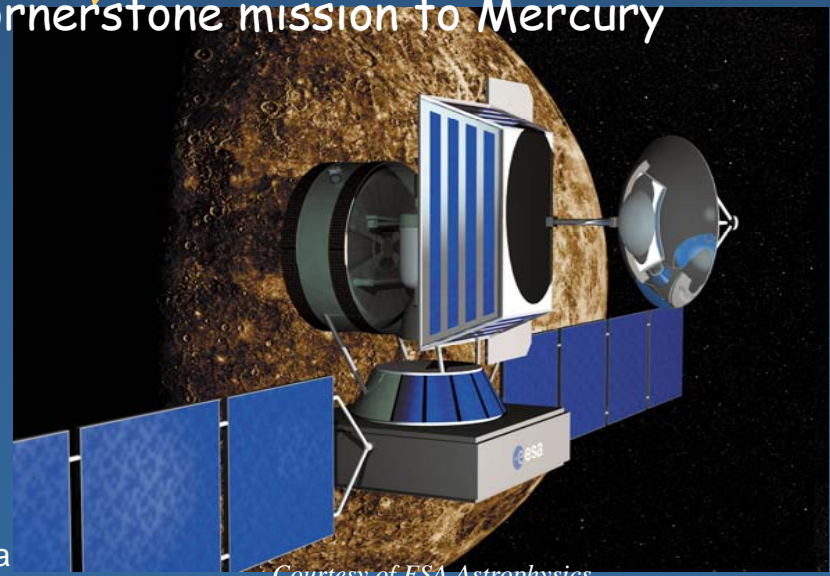

Fluorescence spectrum from Hawaiian basalt:
experimental data and simulation



Detection of Landmines using Radiation Based Techniques

Geant4 User's Workshop, SLAC 2002 02 21

Dr Anthony A. Faust
Threat Detection Group

Defence Research Establishment Suffield

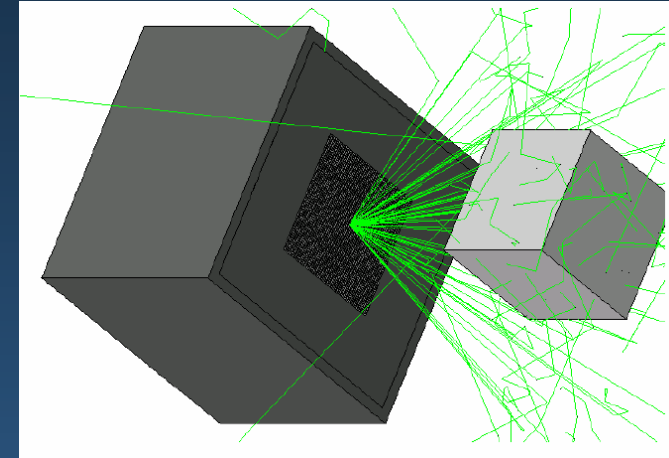

X-ray Backscatter Imaging

- Exploit Z dependent differences in Compton/Photoelectric cross-sections
- $Z_{\text{eff}}^{\text{mine}} \sim 8$ and $Z_{\text{eff}}^{\text{soil}} \sim 14$

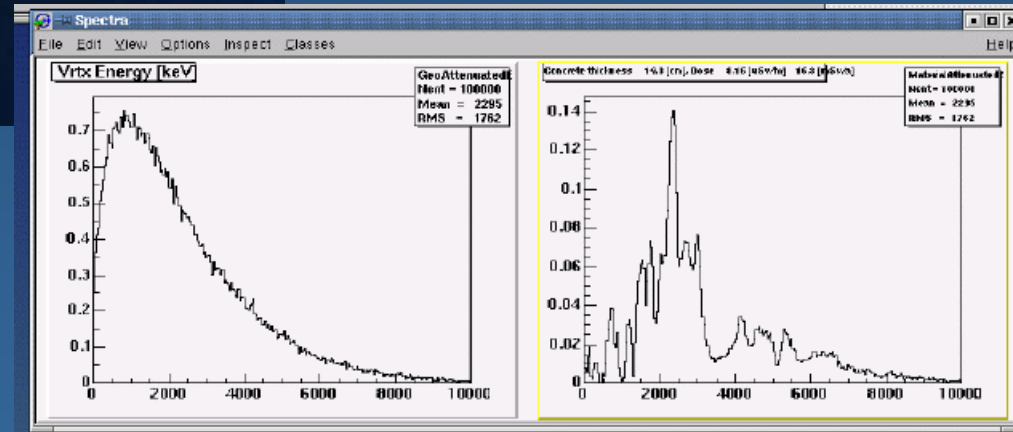

Used Low Energy packages

Polarisation

Cross section:

$$\frac{d\sigma}{d\Omega} = \frac{1}{2} r_0^2 \frac{h\nu^2}{h\nu_0^2} \left[\frac{h\nu_0}{h\nu} + \frac{h\nu}{h\nu_0} - 2 \sin^2 \theta \cos^2 \phi \right]$$

Low Energy Polarised Compton

250 eV - 100 GeV

Sample Methods:

Integrating over ϕ

- Sample θ
- θ - Energy Relation \Rightarrow Energy
- Sample of ϕ from $P(\phi) = a(b - c \cos^2 \phi)$ distribution

$$\cos \xi = \sin \theta \cos \phi \Rightarrow \sin \xi = \sqrt{1 - \sin^2 \theta \cos^2 \phi} = N$$

$$\overline{\varepsilon_{\perp}} = \frac{1}{N} (\cos \theta \hat{j} - \sin \theta \sin \phi \hat{k}) \sin \beta$$

Scattered Photon Polarization

$$\overline{\varepsilon_{\parallel}} = \left(N \hat{i} - \frac{1}{N} \sin^2 \theta \sin \phi \cos \phi \hat{j} - \frac{1}{N} \sin \theta \cos \theta \cos \phi \hat{k} \right) \cos \beta$$

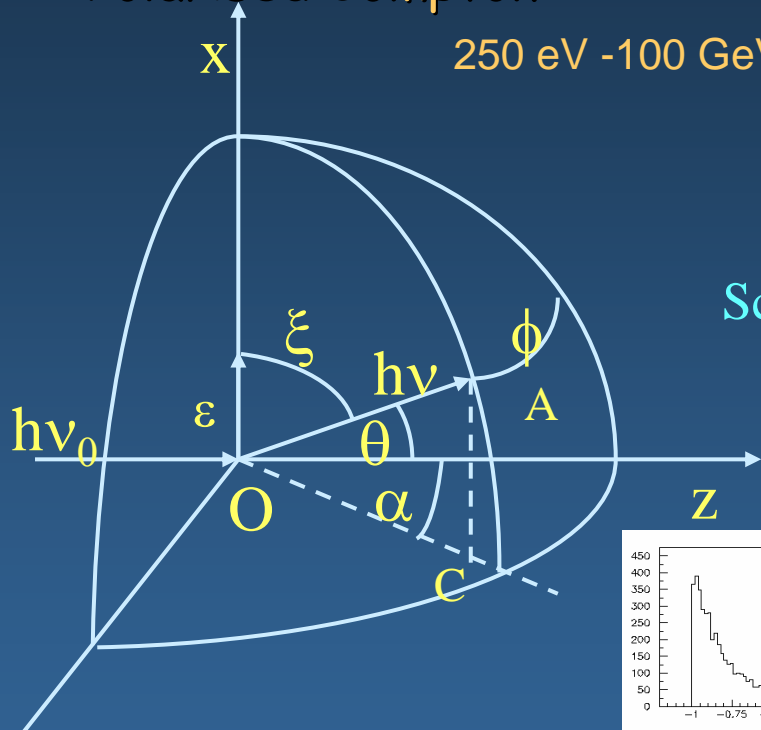

- θ Polar angle
- ϕ Azimuthal angle
- ε Polarization vector

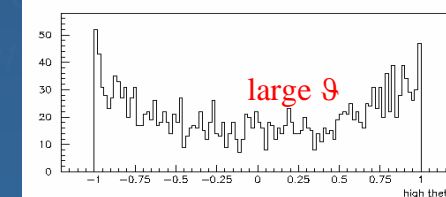
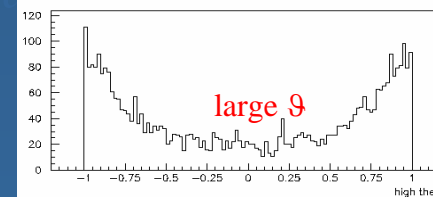
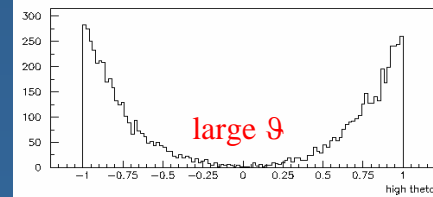
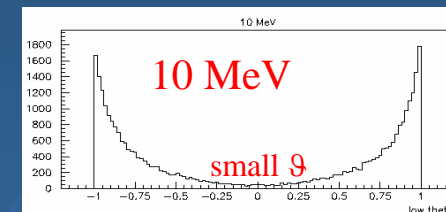
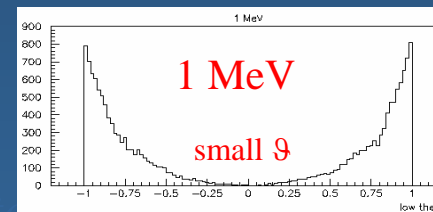
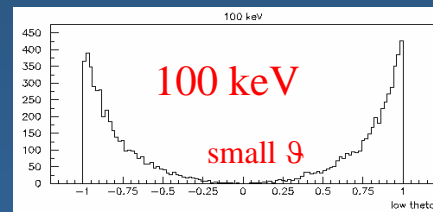

γ astrophysics

γ -ray bursts

BeppoSAX Observation of Gamma-Ray Burst
on February 28, 1997

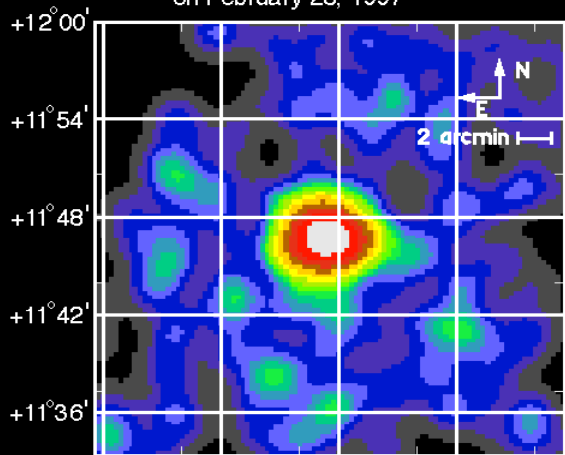

Courtesy of Fabrizio Fiore and the BeppoSAX Team

AGILE

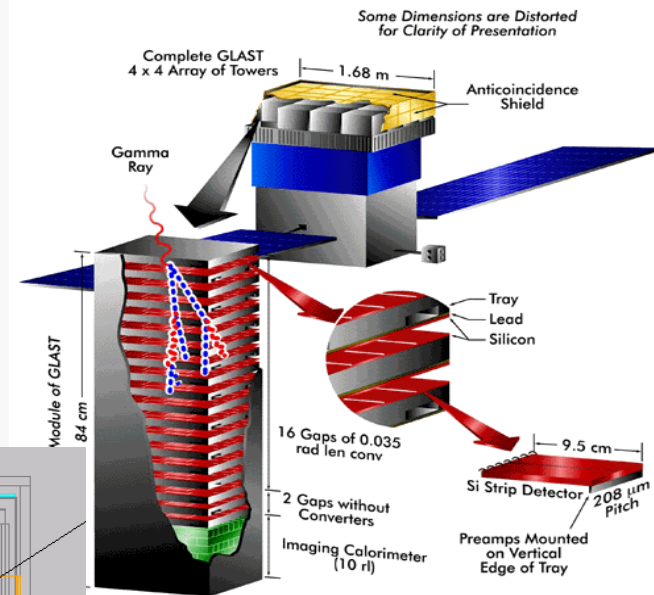
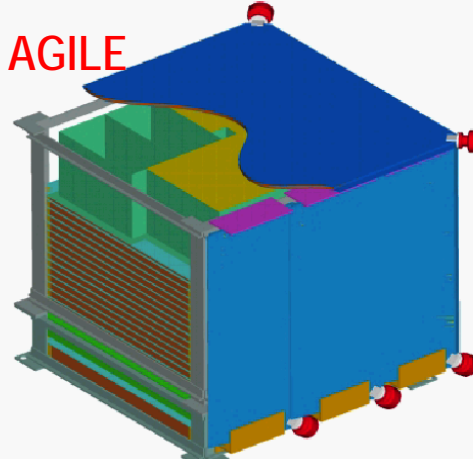

GLAST

GLAST Hits Display

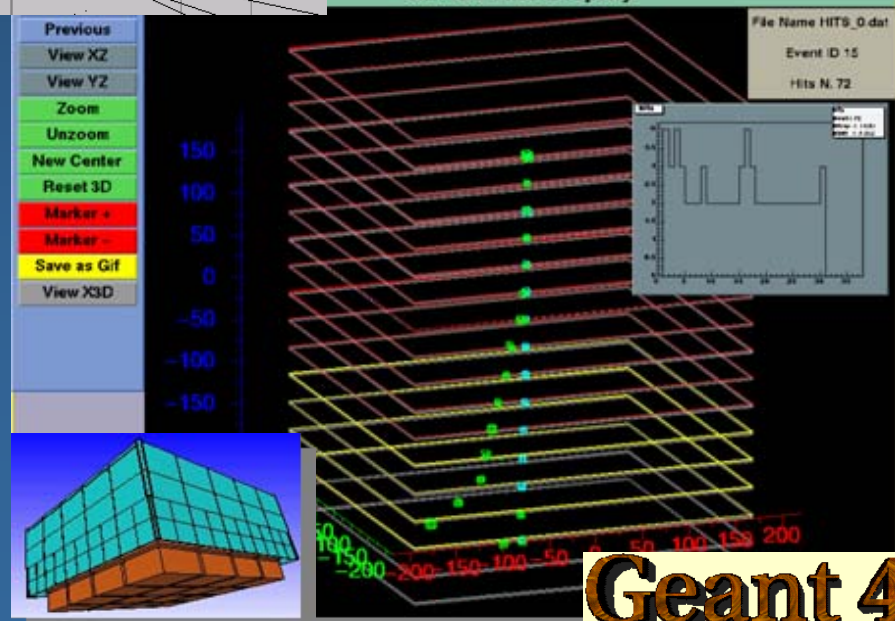

Typical telescope:
Tracker
Calorimeter
Anticoincidence

- γ conversion
- electron interactions
- multiple scattering
- δ -ray production
- charged particle tracking

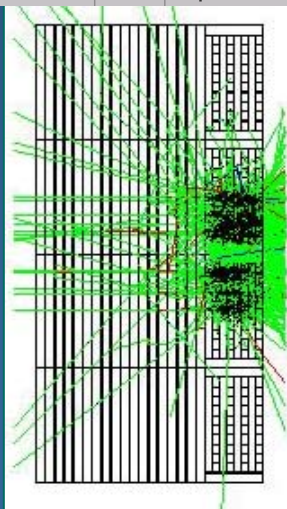

Maria Grazia Pia, INFN Genova

Geant 4

Muons

- 1 keV up to 10 PeV scale
- simulation of ultra-high energy and cosmic ray physics
- High energy extensions based on theoretical models

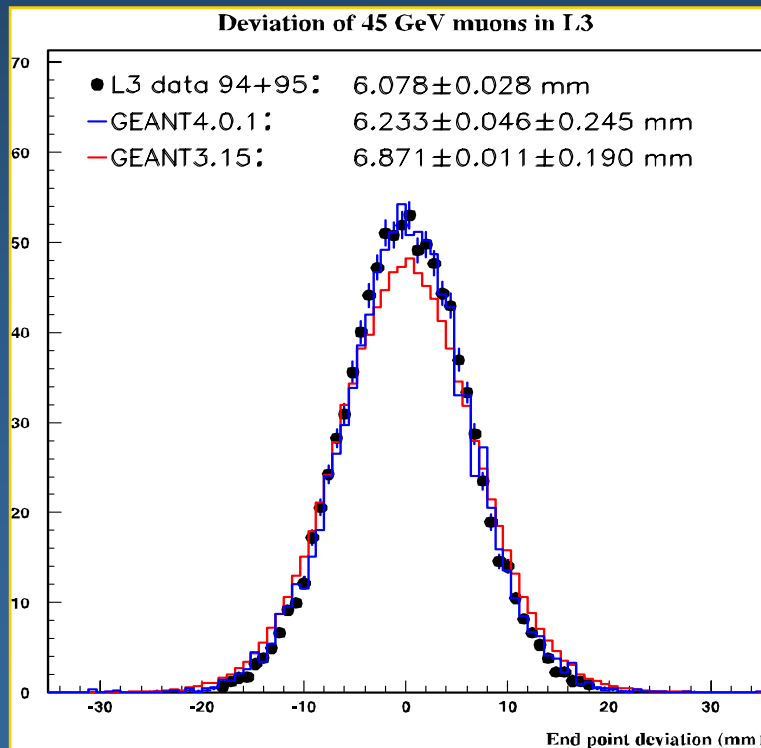

- Muon Muon energy loss
- Muon radiation processes
- Gamma conversion to muon pair
- Positron annihilation to muon pair
- Positron annihilation into hadrons

Optical photons

Production of optical photons in HEP detectors is mainly due to Cherenkov effect and scintillation

Processes in Geant4:

- in-flight absorption
- Rayleigh scattering
- medium-boundary interactions (reflection, refraction)

Geant4 Optical Processes : Scintillating Cells and WLS Fibers

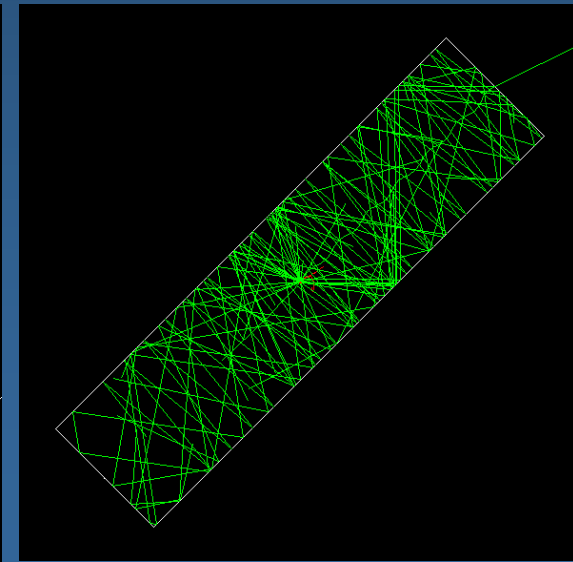
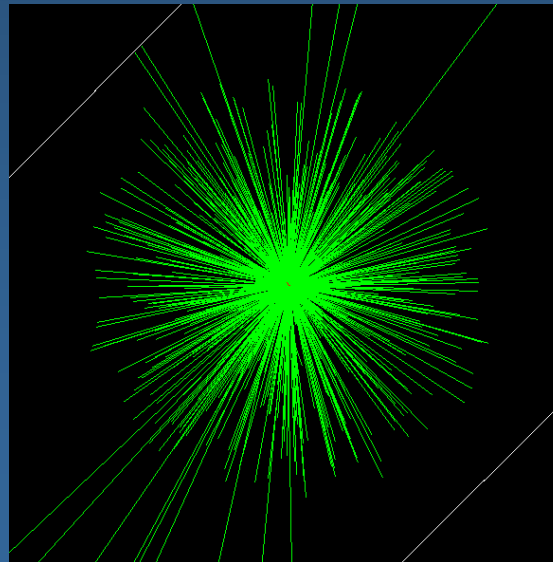
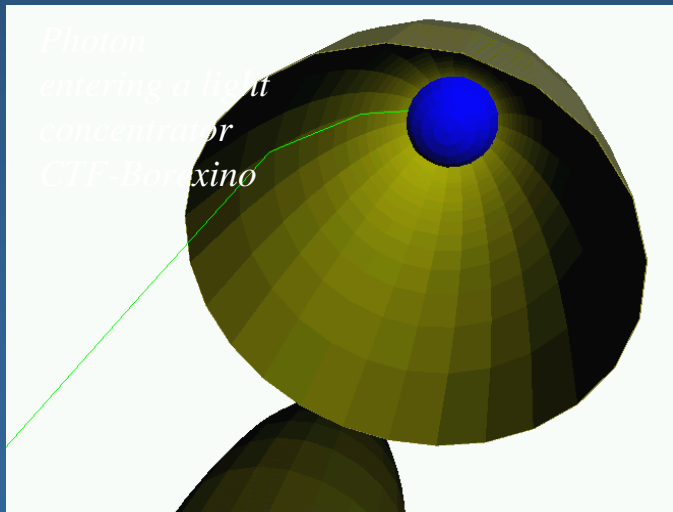

Cherenkov

Milagro is a Water-Cherenkov detector located in a 60m x 80m x 8m covered pond near Los Alamos, NM

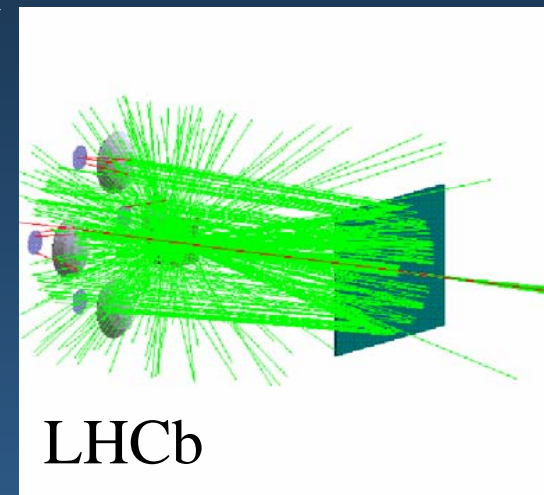
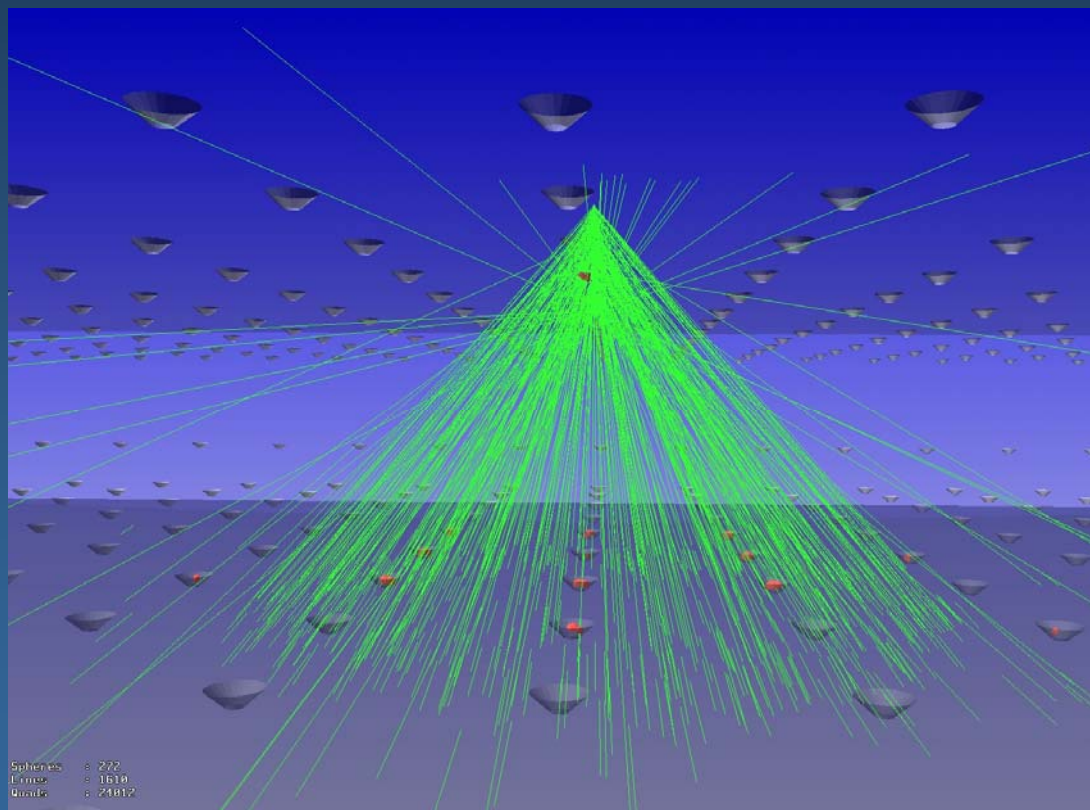

LHCb

Aerogel Thickness	Yield Per Event	Cherenkov Angle mrad
4 cm DATA	6.3 ± 0.7	$247.1^{+5.0}$
MC	7.4 ± 0.8	$246.8^{+3.1}$
8 cm DATA	9.4 ± 1.0	$245.4^{+4.8}$
MC	10.1 ± 1.1	$243.7^{+3.0}$

prompt scintillation

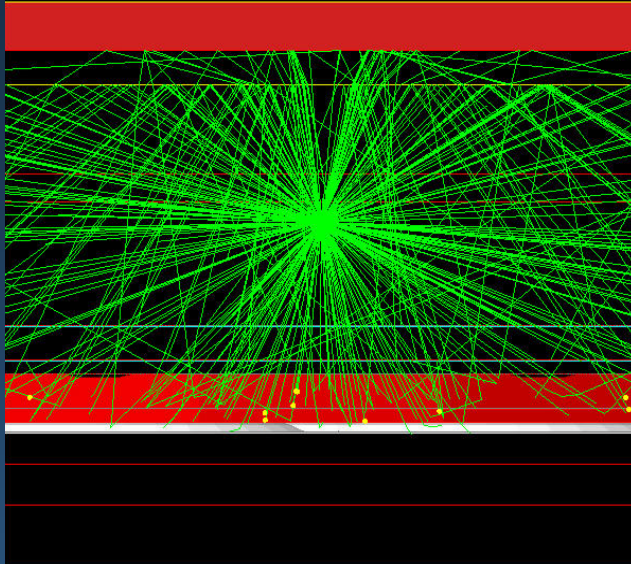

ZEPLIN III
Dark Matter Detector

signal in PMT

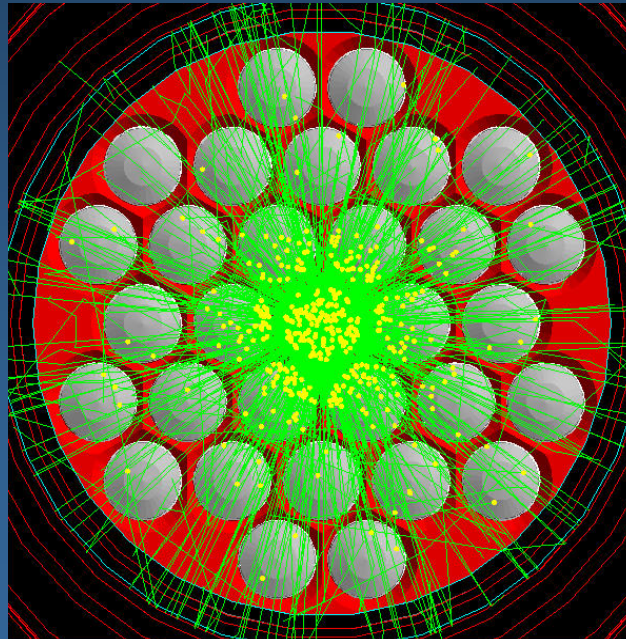

termoluminescence

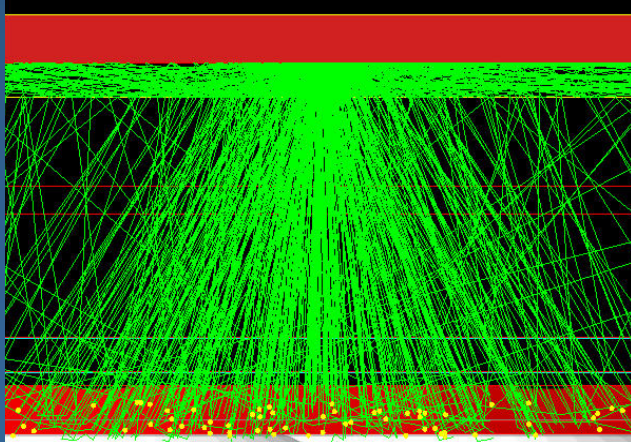

Scintillation

GEANT4 Scintillation
Event in BOREXINO

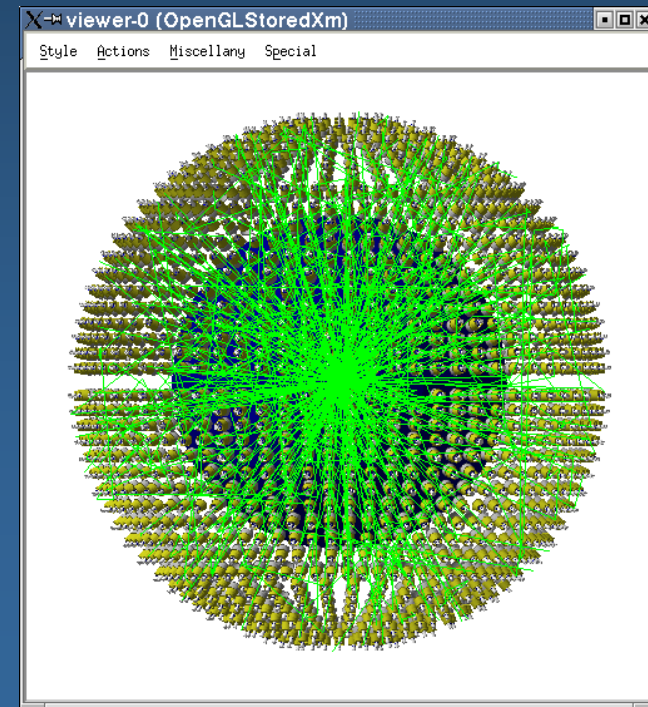

Hadronic physics

- Completely different approach w.r.t. the past (Geant3)
 - native
 - transparent
 - no longer interface to external packages
 - clear separation between data and their use in algorithms
- Cross section data sets
 - transparent and interchangeable
- Final state calculation
 - models by particle, energy, material
- Ample variety of models
 - the most complete hadronic simulation kit on the market
 - alternative and complementary models
 - data-driven, parameterised and theoretical models

Hadronic model inventory

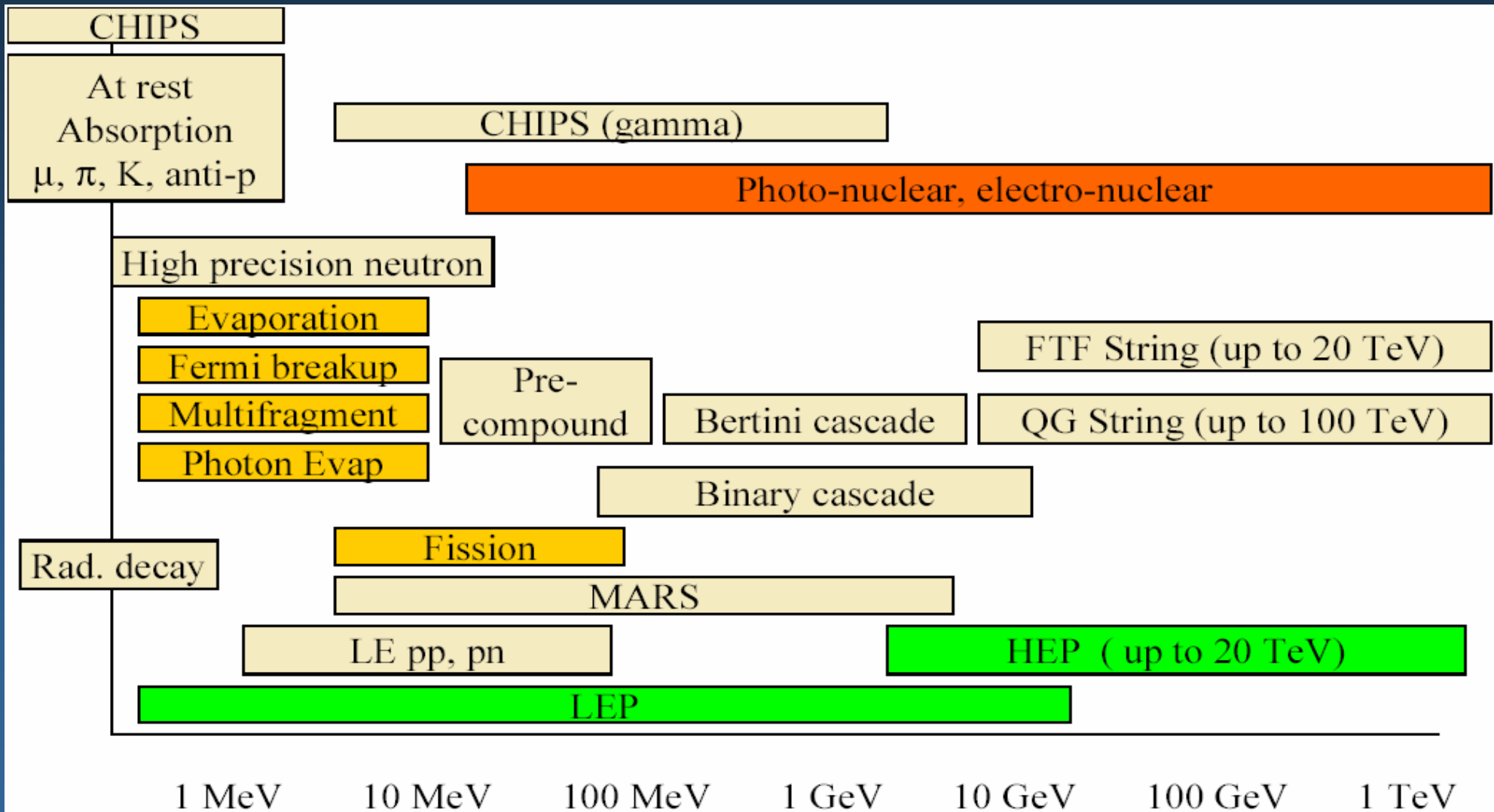

Parameterised and data-driven hadronic models (1)

Based on experimental data

■ Some models originally from GHEISHA

- completely reengineered into OO design
- refined physics parameterisations

■ New parameterisations

- pp, elastic differential cross section
- nN, total cross section
- pN, total cross section
- np, elastic differential cross section
- πN , total cross section
- πN , coherent elastic scattering

p elastic scattering on Hydrogen

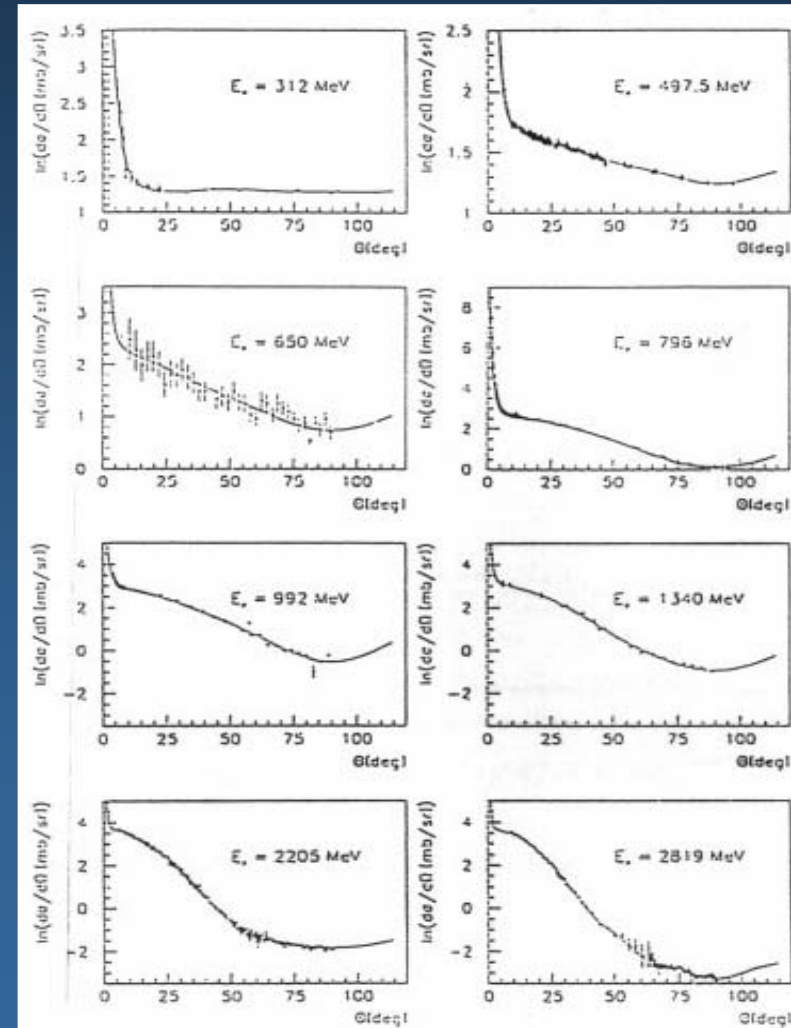

$(\pi^+, K^+)A$ at 250 GeV/c

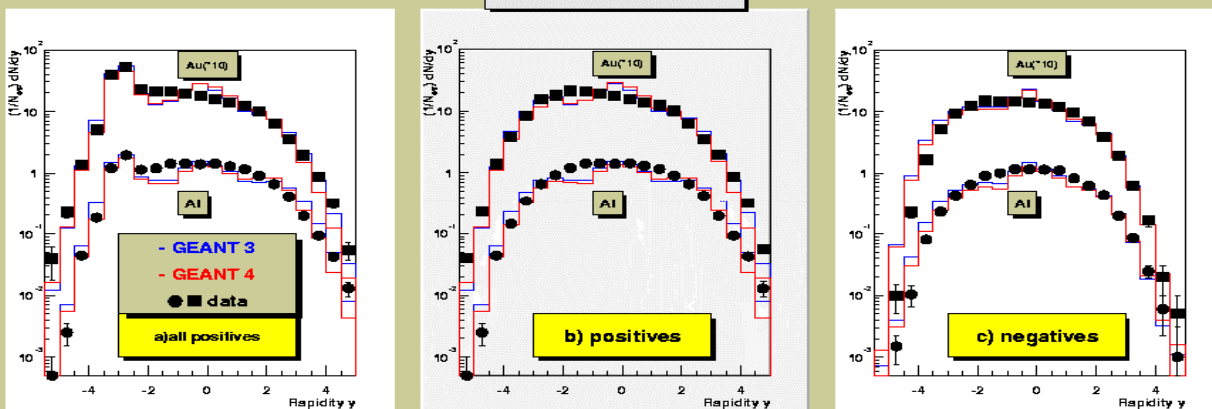

Parameterised and data-driven hadronic models (2)

Other models are completely new, such as:

stopping particles: π^- , K^-
(relevant for μ/π PID detectors)

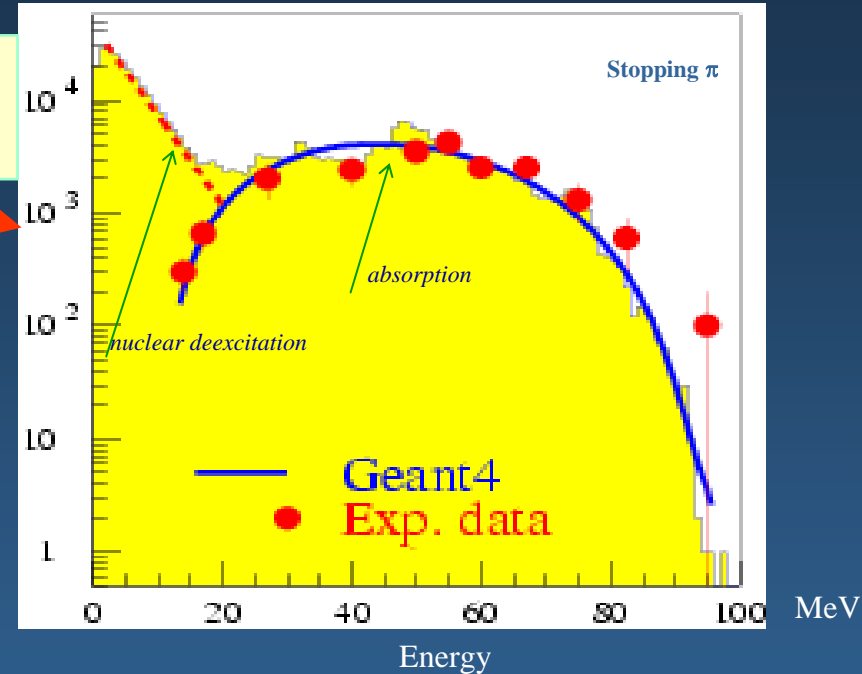
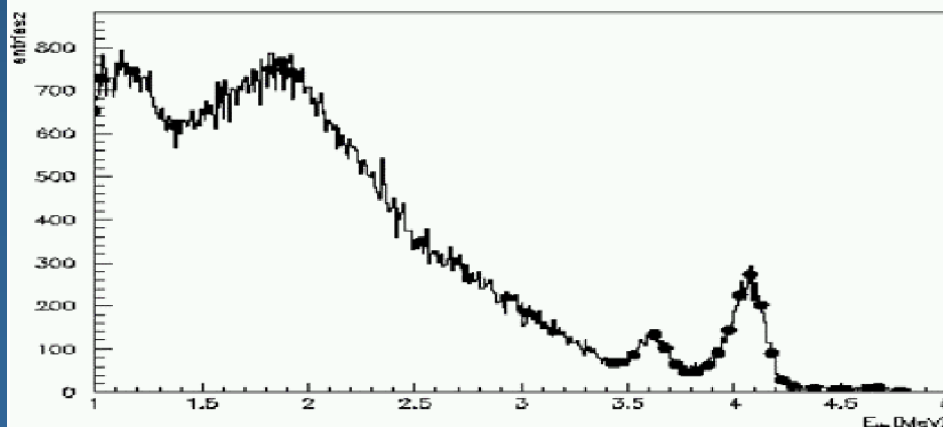
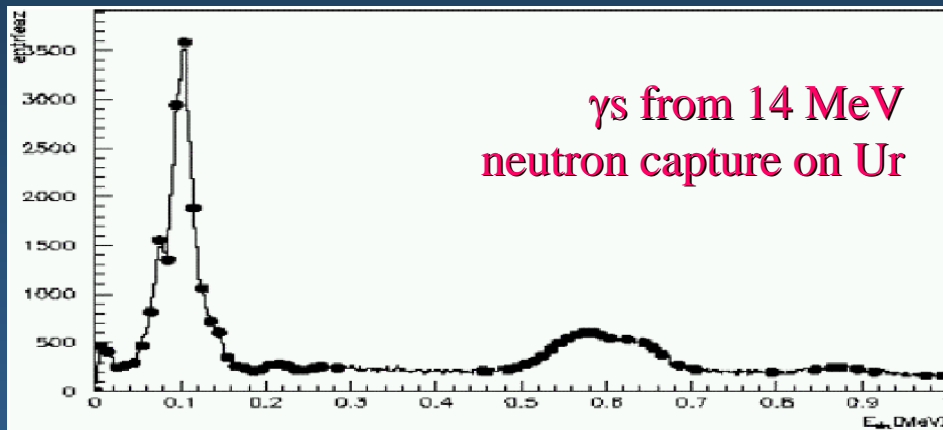

neutrons

All worldwide existing databases
used in **neutron** transport
Brond, CENDL, EFF, ENDFB, JEF,
JENDL, MENDL etc.

Theory-driven models

- Complementary and alternative models
- Evaporation phase*
- Low energy range O(100 MeV): *pre-equilibrium*
- Intermediate energy range, O(100 MeV) to O(5 GeV): *intra-nuclear transport*
- High energy range: *hadronic generator* régime

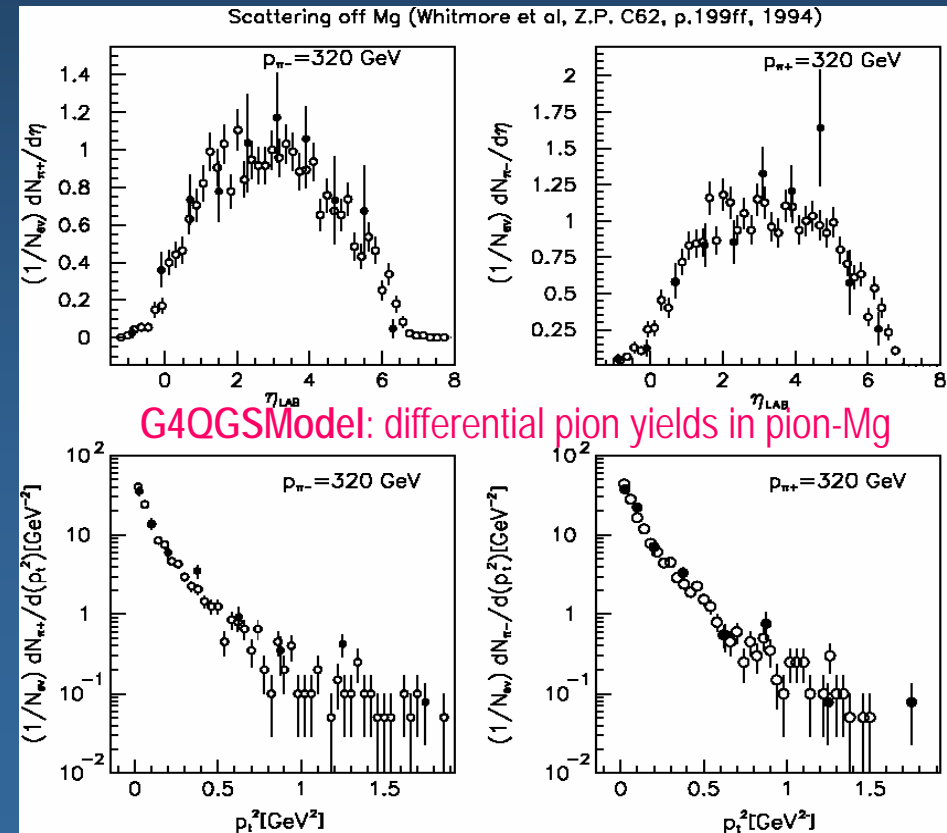
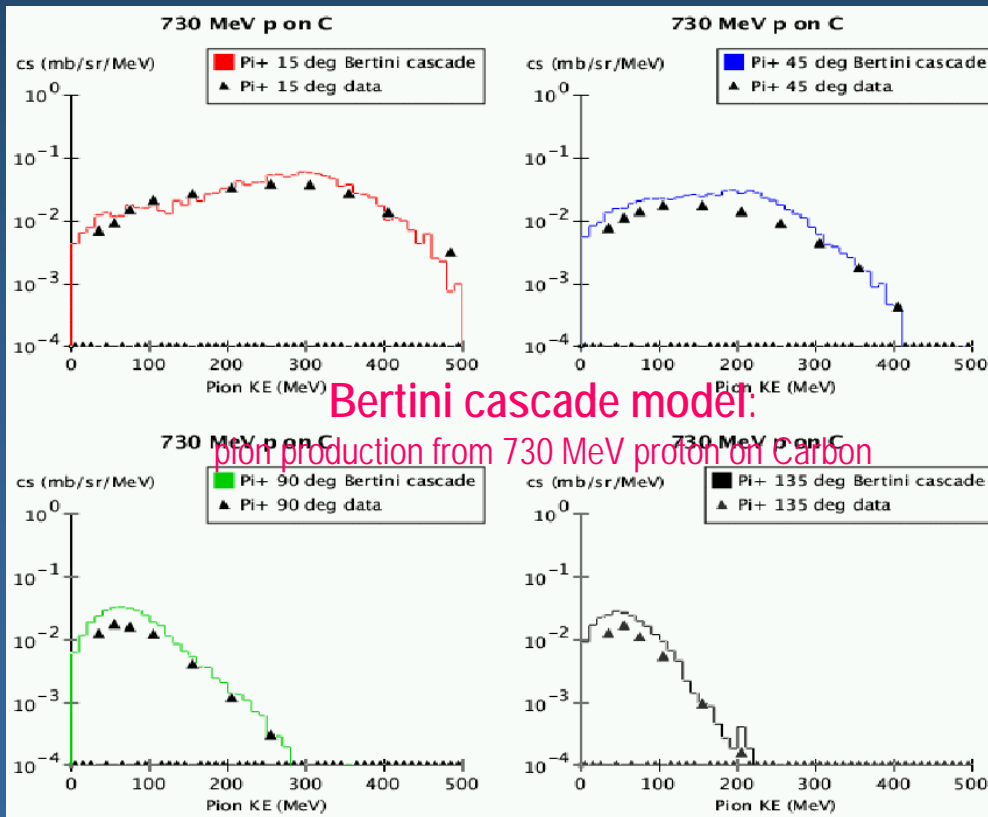

The two worlds can be mixed...

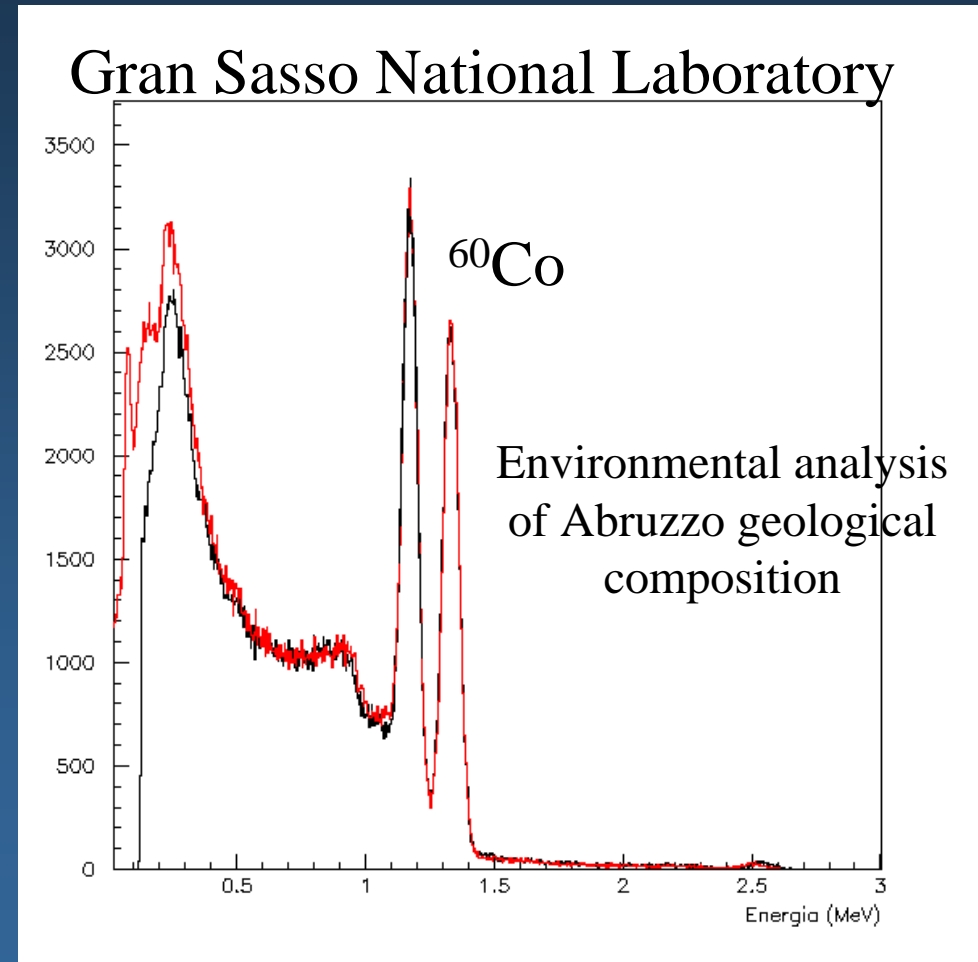
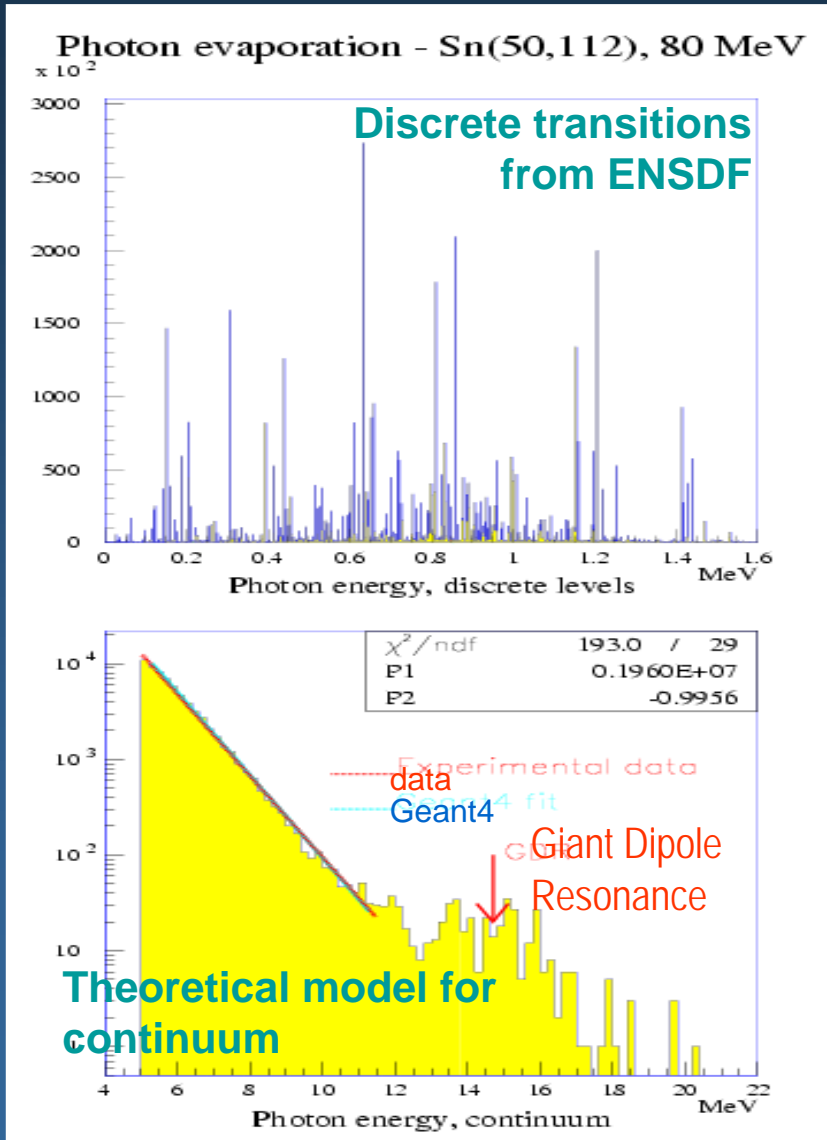

Other components

■ Materials

- elements, isotopes, compounds, chemical formulae

■ Particles

- all PDG data
- and more, for specific Geant4 use, like ions

■ Hits & Digi

- to describe detector response

■ Primary event generation

- some general purpose tools provided within the Toolkit
 - eg. GeneralParticleSource

■ ...and much more (no time to mention all!)

read-out geometry
event biasing
fast simulation
parallelisation
persistency
much more physics
etc.

Interface to external tools in Geant4

Through abstract interfaces

no dependence
minimize coupling of components

Similar approach

- Visualisation
- (G)UI
- Persistency
- Analysis

The user is free to choose the concrete system he/she prefers for each component

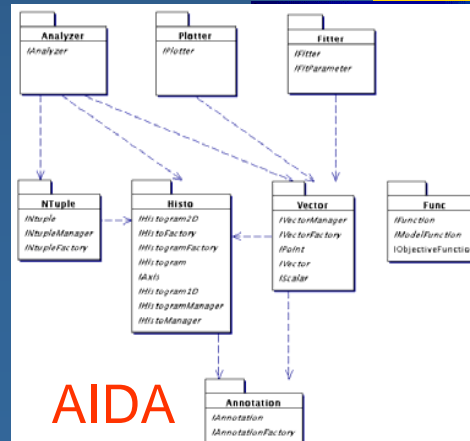
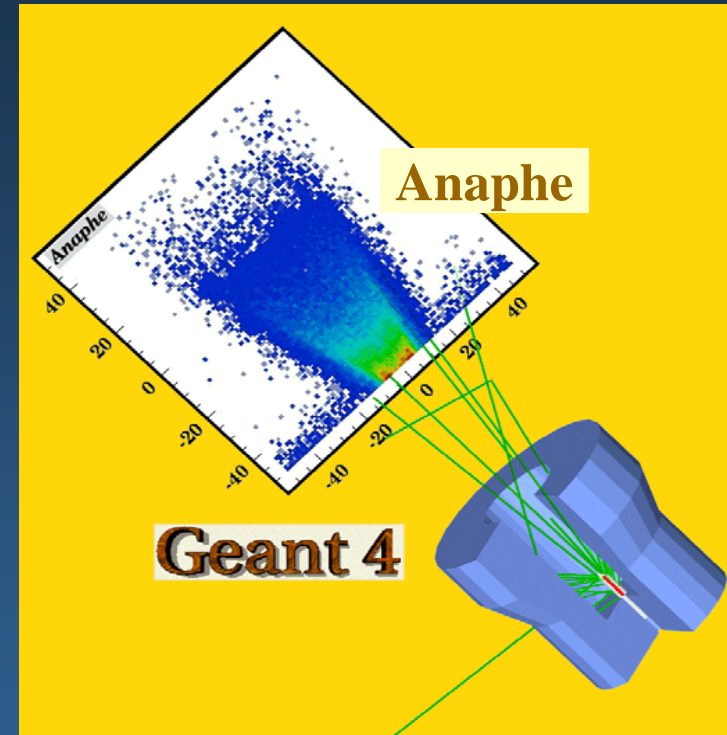

AIDA

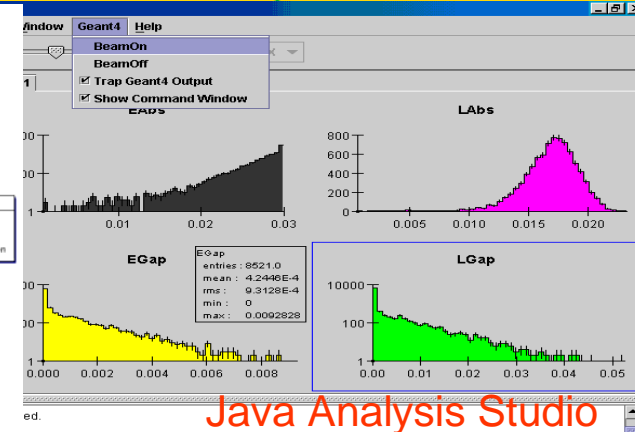

Java Analysis Studio

User Interface

- Several implementations, all handled through abstract interfaces
- Command-line (batch and terminal)
- GUIs
 - X11/Motif, GAG, MOMO, OPACS, Java

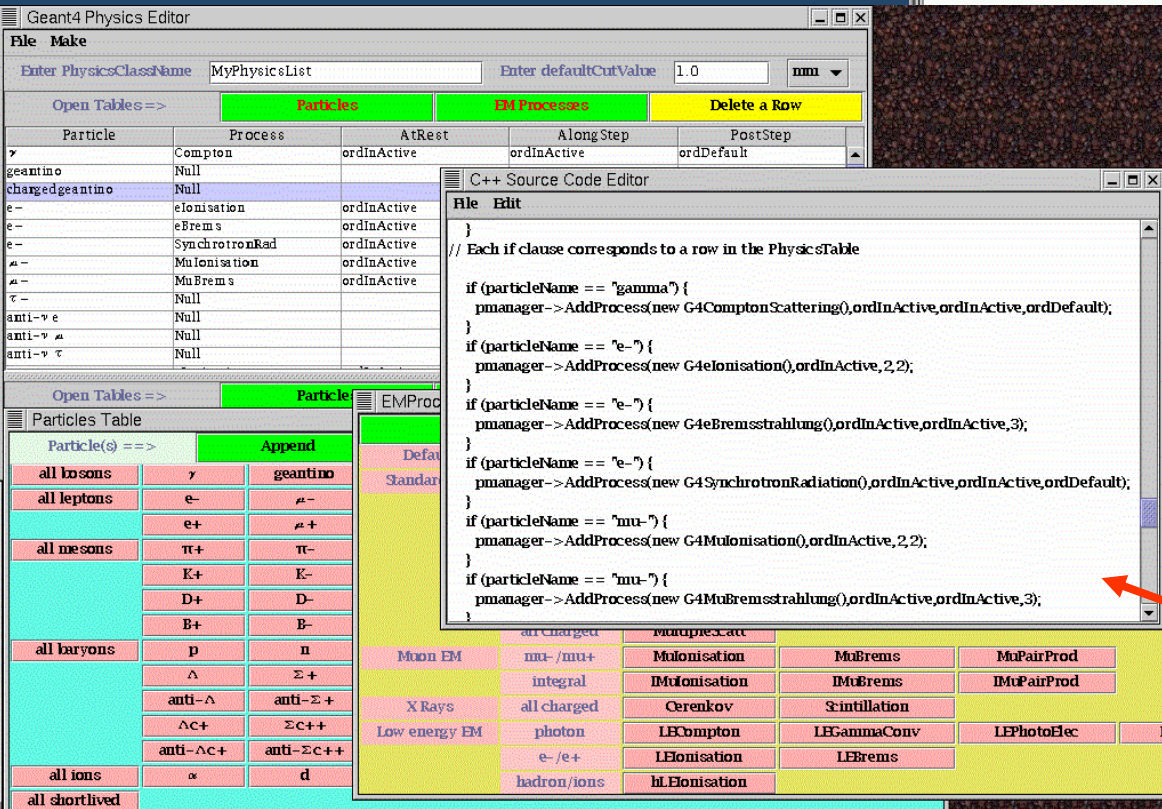
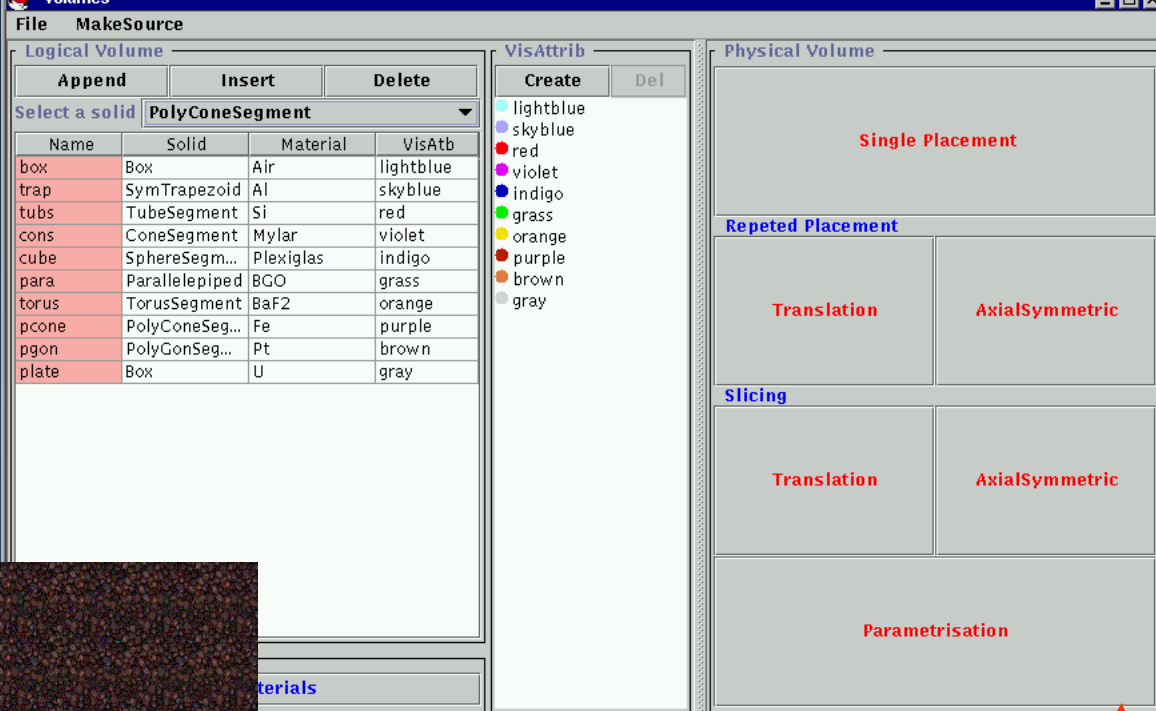

Automatic code generation for geometry and physics through a GUI

- GGE (Geant4 Geometry Editor)
- GPE (Geant4 Physics Editor)

Visualisation

■ Control of several kinds of visualisation

- detector geometry
- particle trajectories
- hits in the detectors

■ Various drivers

- OpenGL
- OpenInventor
- X11
- Postscript
- DAWN
- OPACS
- HepRep
- VRML...

■ all handled through abstract interfaces

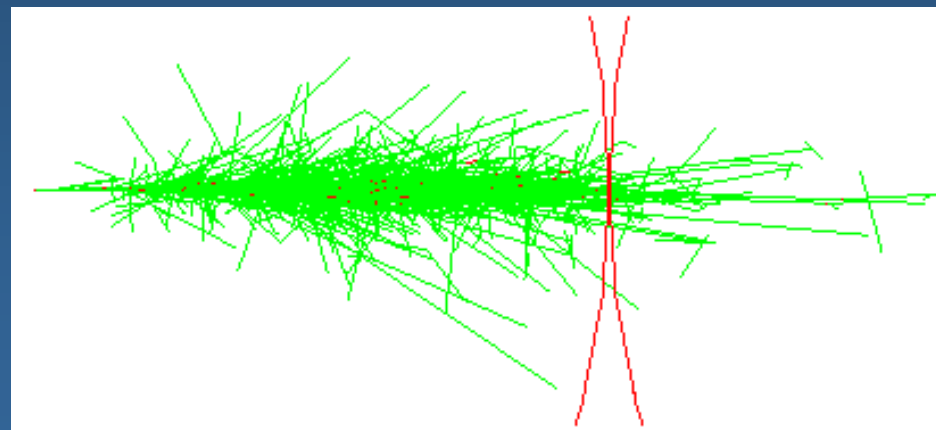
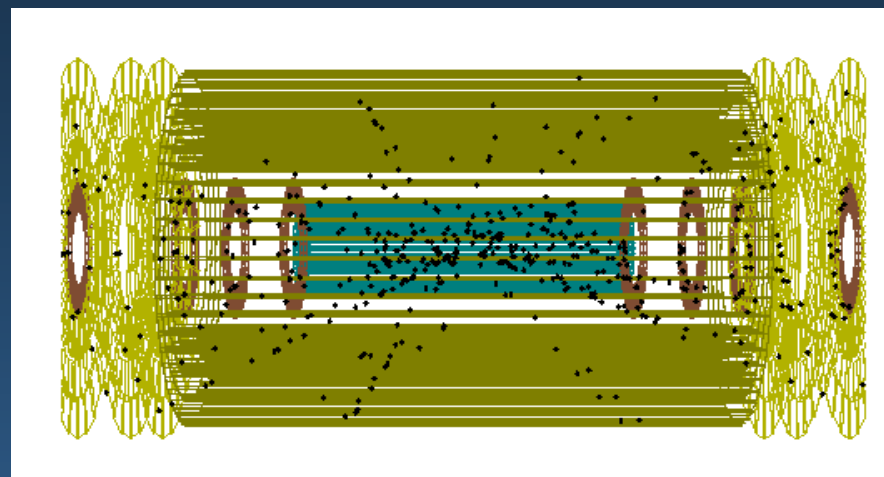

Pushing Geant4 to the limit

Heavy ion beams

MIRS N. Kanematsu, M. Komori - Nagoya K. Niwa, T. Toshito, T. Nakamura, T. Ban, N. Naganawa, S. Takahashi - Uchu-ken M. Ozaki - Kobe S. Aoki - Aichi Y. Kodama - Naruto H. Yoshida - Ritsumei S. Tanaka - SLAC M. Asai, T. Koi - Tokyo N. Kokubu - Gunma K. Yusa - Toho H. Shibuya, R. Ogawa, A. Shibazaki, T. Fukushima - KEK K. Amako, K. Murakami, T. Sasaki

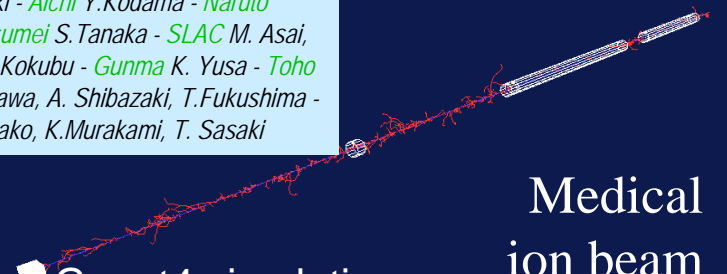

Medical ion beam

Geant4 simulation

Beam Track Reconstruction
135 MeV/u ^{12}C beam

Cylinders : 14
Cubes : 6226
Lines : 51678

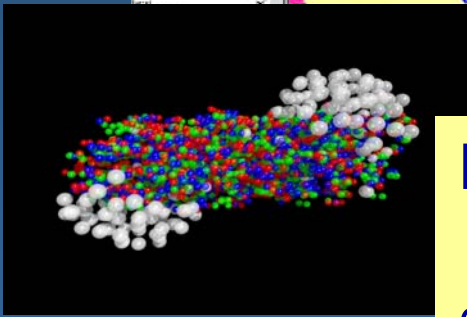
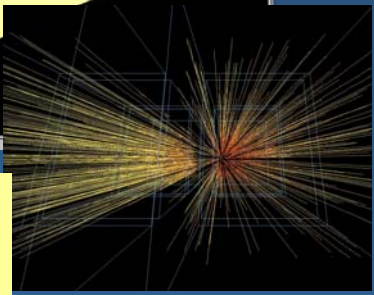
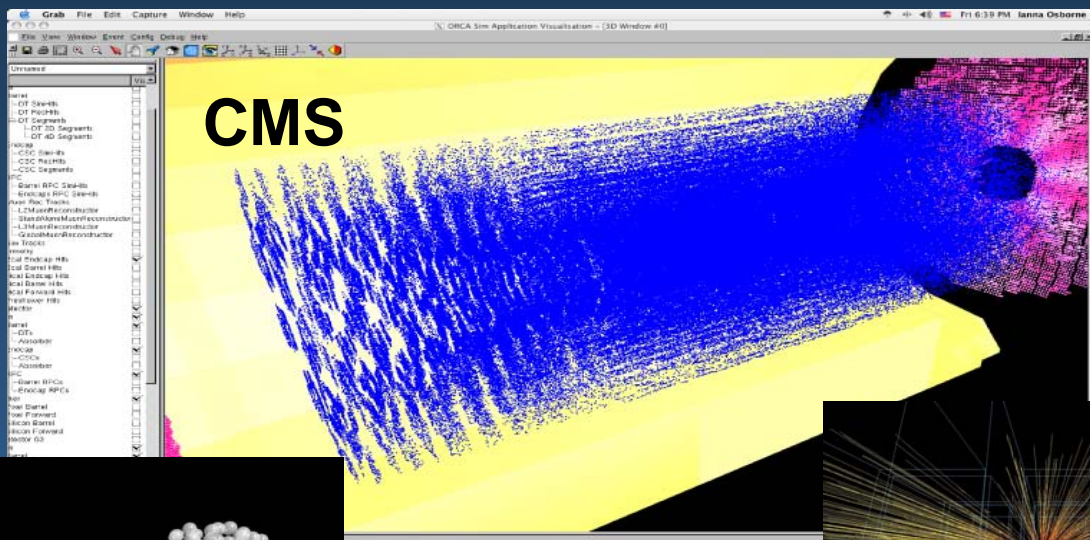

Events with > 50000 particles/event in detector acceptance

~ 180 minutes to simulate 1 event with 55K generator tracks

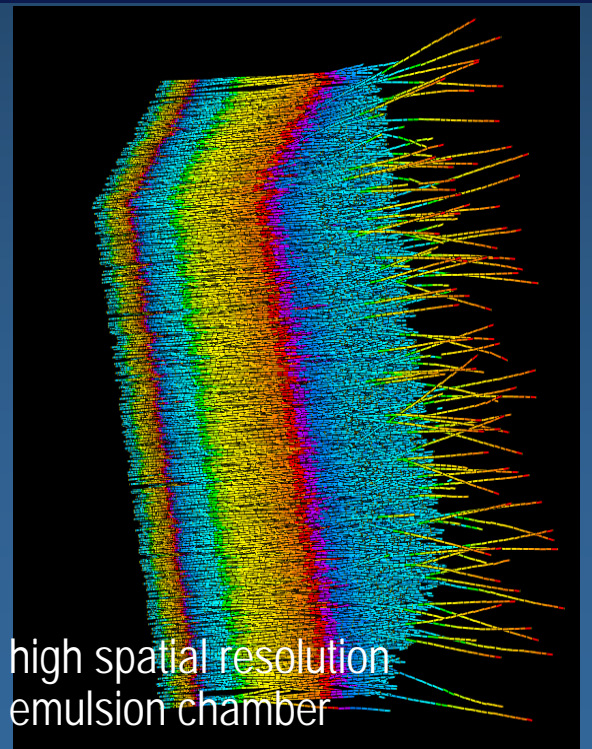

high spatial resolution emulsion chamber

LISA (gravitational waves)

Geant4 relevant for evaluation of space
charging effects

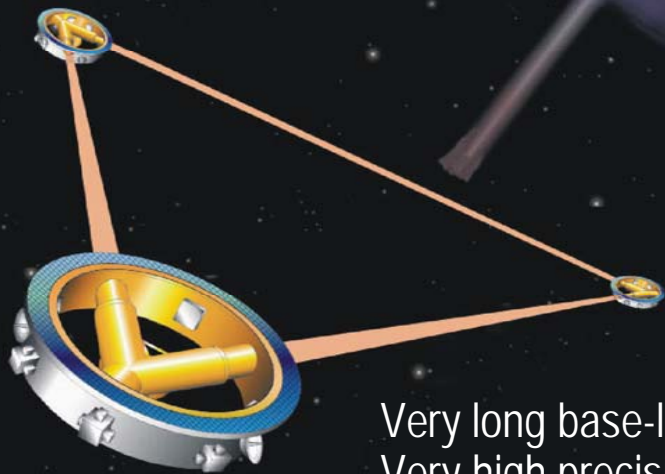

Very long base-line: 1 million km
Very high precision: $< 1\text{ nm} - 1\text{ pm}$ (!)

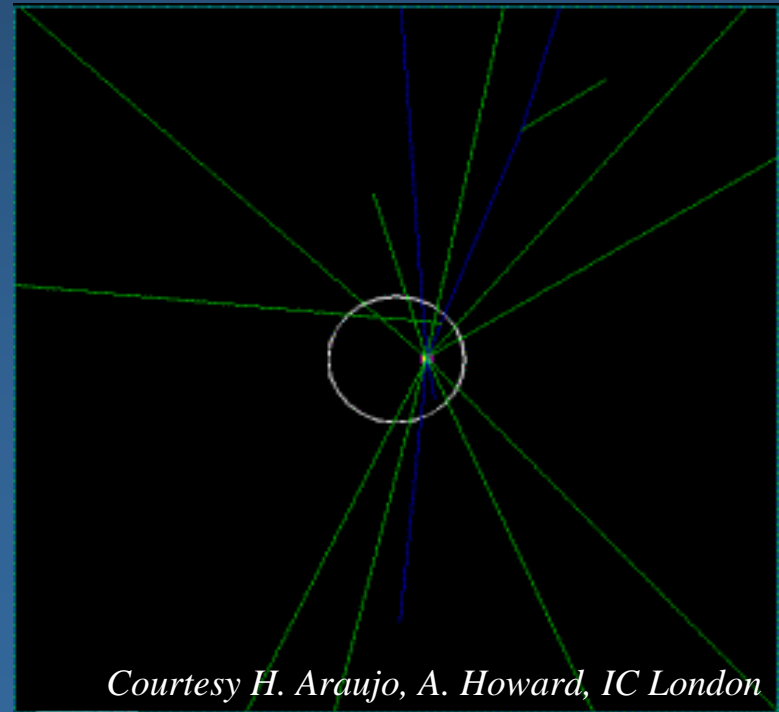
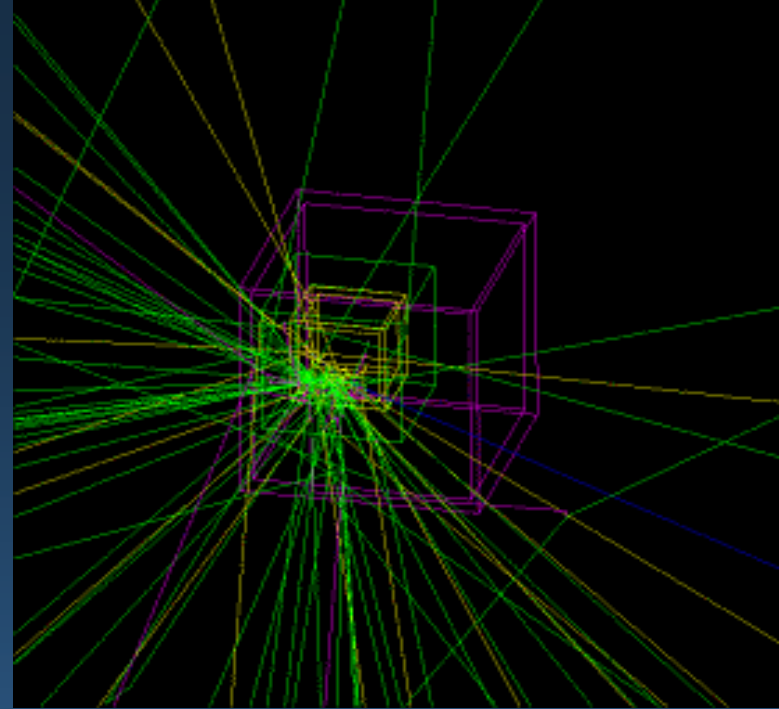

Is it worthwhile?

Comparison with commercial radiotherapy treatment planning systems

M. C. Lopes

IPOFG-CROC Coimbra Oncological Regional Center

L. Peralta, P. Rodrigues, A. Trindade

LIP - Lisbon

$$\chi^2/ndf \text{ (GEANT 4)} = 0.52$$

$$\chi^2/ndf \text{ (TMS)} = 0.81$$

$$\chi^2/ndf \text{ (PLATO)} = 6.71$$

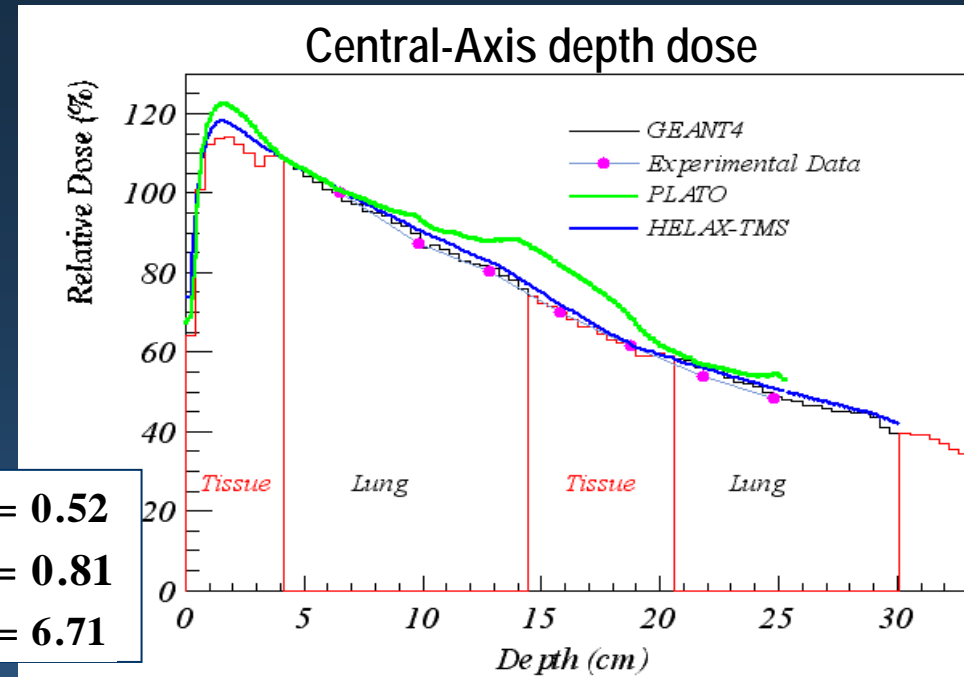

CT-simulation with a Rando phantom
Experimental data with TLD LiF dosimeter

CT images used to define the geometry:
a thorax slice from a Rando anthropomorphic phantom

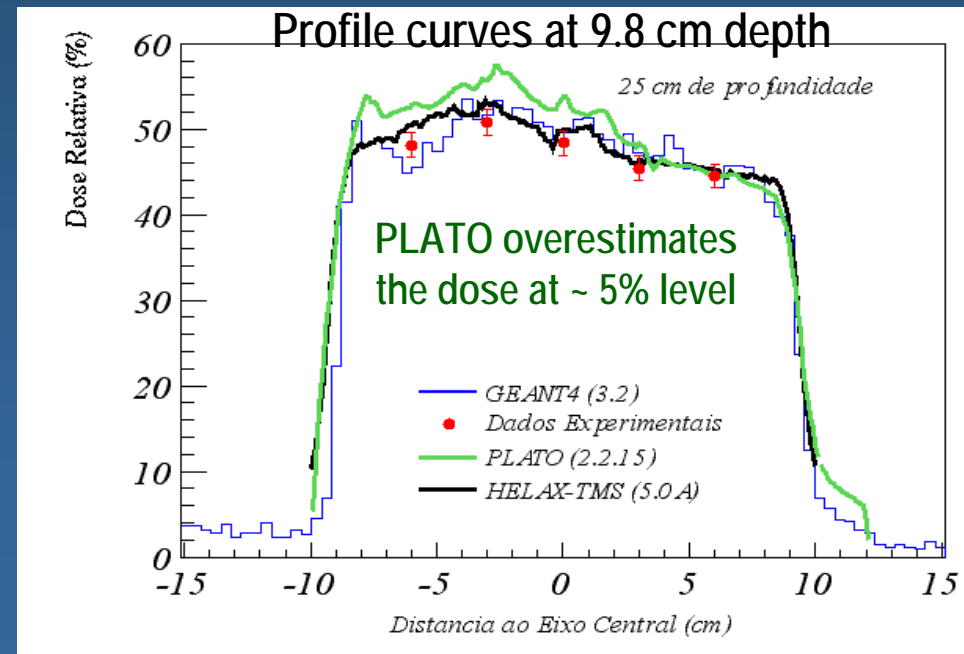
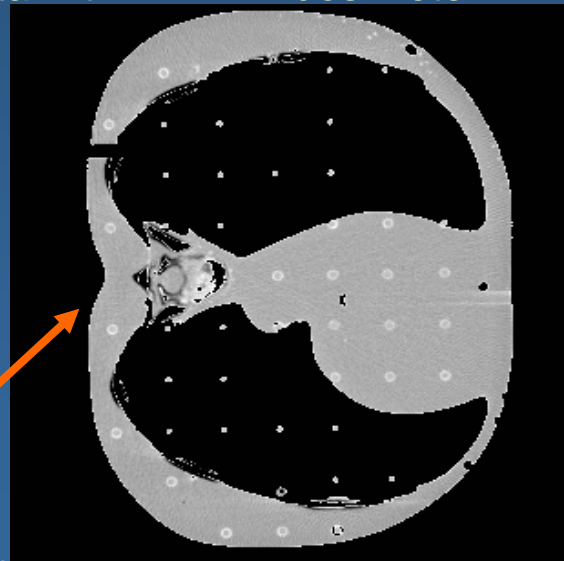

Access to distributed computing

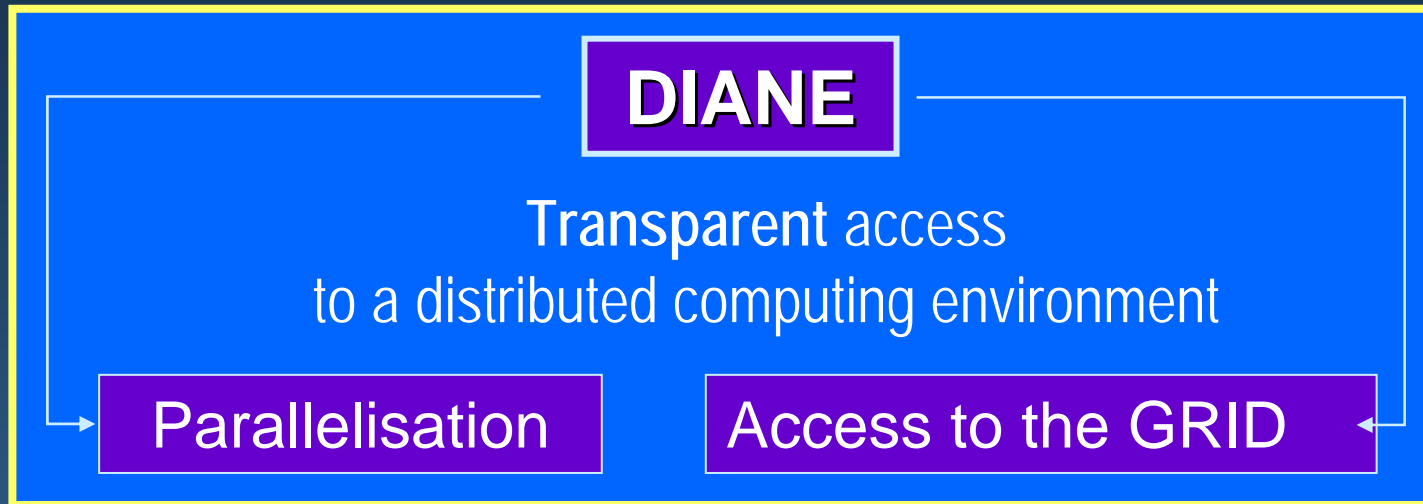

- Required production of *Brachytherapy*: 20 M events
- 20 M events in sequential mode: 16646 s (~ 4h 38')
on an Intel ® Pentium IV, 3.00 GHz
- The same simulation runs in 5' in parallel on 56 CPUs
– appropriate for clinical usage

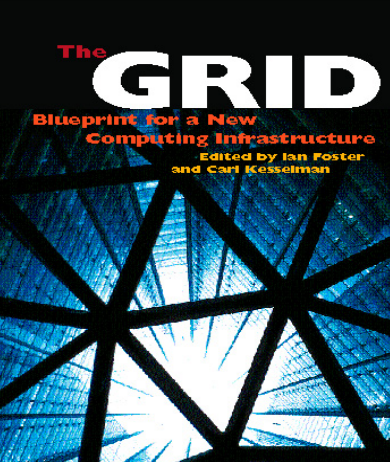

Traceback from a run on CrossGrid testbed



Current #Grid setup (computing elements):
5000 events, 2 workers, 10 tasks (500 events each)

Resource broker running in Portugal

matchmaking CrossGrid computing elements

- aocegrid.uab.es:2119/jobmanager-pbs-workq
- bee001.ific.uv.es:2119/jobmanager-pbs-qgrid
- cgnode00.di.uoa.gr:2119/jobmanager-pbs-workq
- cms.fuw.edu.pl:2119/jobmanager-pbs-workq
- grid01.physics.auth.gr:2119/jobmanager-pbs-workq
- xg001.inp.demokritos.gr:2119/jobmanager-pbs-workq
- xgrid.icm.edu.pl:2119/jobmanager-pbs-workq
- zeus24.cyf-kr.edu.pl:2119/jobmanager-pbs-infinite
- zeus24.cyf-kr.edu.pl:2119/jobmanager-pbs-long
- zeus24.cyf-kr.edu.pl:2119/jobmanager-pbs-medium
- zeus24.cyf-kr.edu.pl:2119/jobmanager-pbs-short
- ce01.lip.pt:2119/jobmanager-pbs-qgrid

Spain

Greece

Poland

Portugal

GATE

a Geant4 based simulation
platform,
designed for PET and SPECT

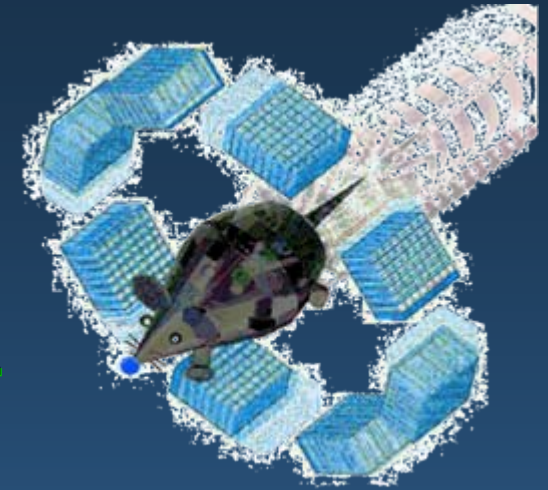

GATE Collaboration

Recently released as
an open source
software system
under GPL

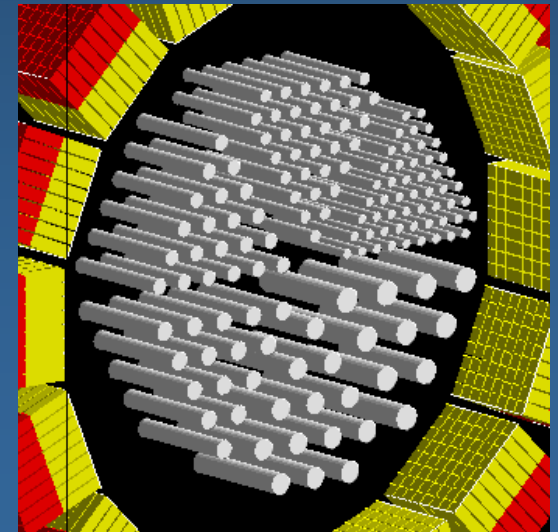
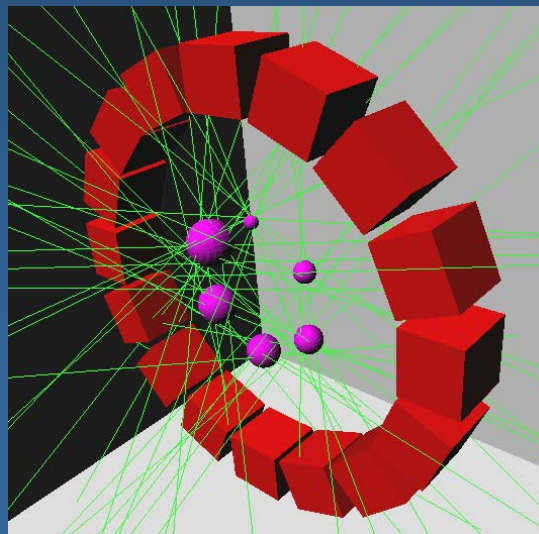

Robustness

TM & © NIKHEF



BaBar Simulation Production

BaBar simulation production – a millennium of work in under a year.

D. A. Smith, D. Andreotti, F. Blanc, C. Bozzi, A. Khan
for the BaBar computing group.

IEEE 2004 - Oct. 21, 2004

Data Challenges in LHC experiments

The **Geant 4** kit

■ Code

- ~1M lines of code
- continuously growing
- publicly downloadable from the web

■ Documentation

- 5 manuals
- publicly available from the web

■ Examples

- distributed with the code
- various complete applications of (simplified) real-life experimental set-ups

■ Platforms

- Linux, SUN, Windows, (MacOS)

■ Commercial software

- None required
- Can be interfaced

■ Free software

- CVS
- gmake, g++
- CLHEP

■ Graphics & (G)UI

- OpenGL, X11, OpenInventor, DAWN, VRML...
- OPACS, GAG, MOMO...

■ Persistency

- it is possible to run in transient mode
- in persistent mode use a HepDB interface, ODMG standard



Geant4 Collaboration

MoU based

Development, Distribution and User Support of Geant4



Major physics laboratories:
CERN, KEK, SLAC, TRIUMF, TJNL



European Space Agency:
ESA



National Institutes:
INFN, IN2P3, PPARC



Universities:

Budker Inst., Frankfurt Univ., Karolinska Inst., Helsinki Univ.,
Lebedev Inst., LIP, Northeastern Univ. *etc.*



21-121 members in the RD44 phase, ~ 60 currently

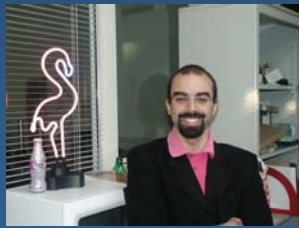

INF



The next frontier

The power of abstract interfaces



Geant 4 DNA



Simulation of Interactions of Radiation with Biological Systems at the Cellular and DNA Level

Estimating cancer risk for human exposures to space radiation is a challenge which involves a wide range of knowledge in physics, chemistry, biology and medicine.

Traditionally, the biological effects of radiation are analysed in top-bottom order, i.e. evaluation of the absorbed macroscopic radiation dose at a given location in the biological tissue is translated to the degree of danger it presents, and dose limits are consequently set that are considered to be acceptable.

A novel approach, based on the new-generation object-oriented **Geant4** Monte Carlo Toolkit, proceeds in a reverse order, from bottom to top, by analysing the nano-scale effects of energetic particles at the cellular and DNA molecule level.

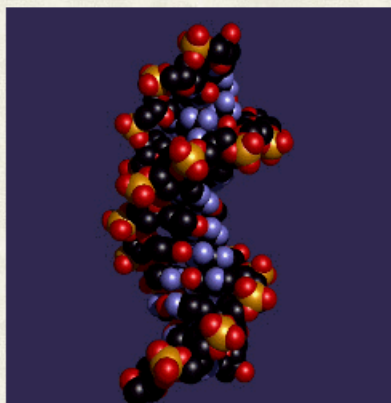

This project is sponsored by the European Space Agency (ESA) and is pursued by a multidisciplinary European team of biologists, physicians, physicists, space scientists and software engineers.

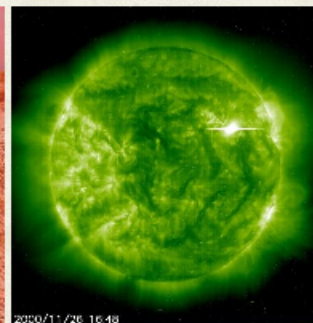

- Home
- Requirements
- Documents
- Talks
- Papers
- Meetings
- Team

- Geant4
- Geant4-INFN
- Geant4 LowE Physics

- Useful links

Geant 4 for medicine

■ Macroscopic

- calculation of dose
- medical imaging
- already feasible with Geant4
- develop useful associated tools

■ Cellular level

- cell modelling
- processes for cell survival, damage etc.

■ DNA level

- DNA modelling
- physics processes at the eV scale
- processes for DNA strand breaking, repair etc.

Complexity of
software, physics and biology
addressed with an iterative and
incremental software process



Parallel development at
all the three levels
(domain decomposition)

Conclusions

Complexity of physics, detectors, environments

A rapidly changing computing environment

Similar requirements across diverse fields (HEP, astrophysics, medicine...)

The response:

- rigorous approach to software engineering
- OO technology
- powerful functionality, rich physics

Achieve:

- openness to extension and evolution
- maintainability over an extended time scale
- transparency of physics

Results:

- HEP, space science, medical physics...
- science + technology transfer